



2018

SCNC

SKILLS CANADA
NATIONAL COMPETITION

OCMT

OLYMPIADES CANADIENNES
DES MÉTIERS ET
DES TECHNOLOGIES



skillsCompétences
Canada
Edmonton2018

PROJET D'ÉPREUVE / TEST PROJECT

TÔLERIE

SHEET METAL WORK

NIVEAUX POSTSECONDAIRE /
POST - SECONDARY



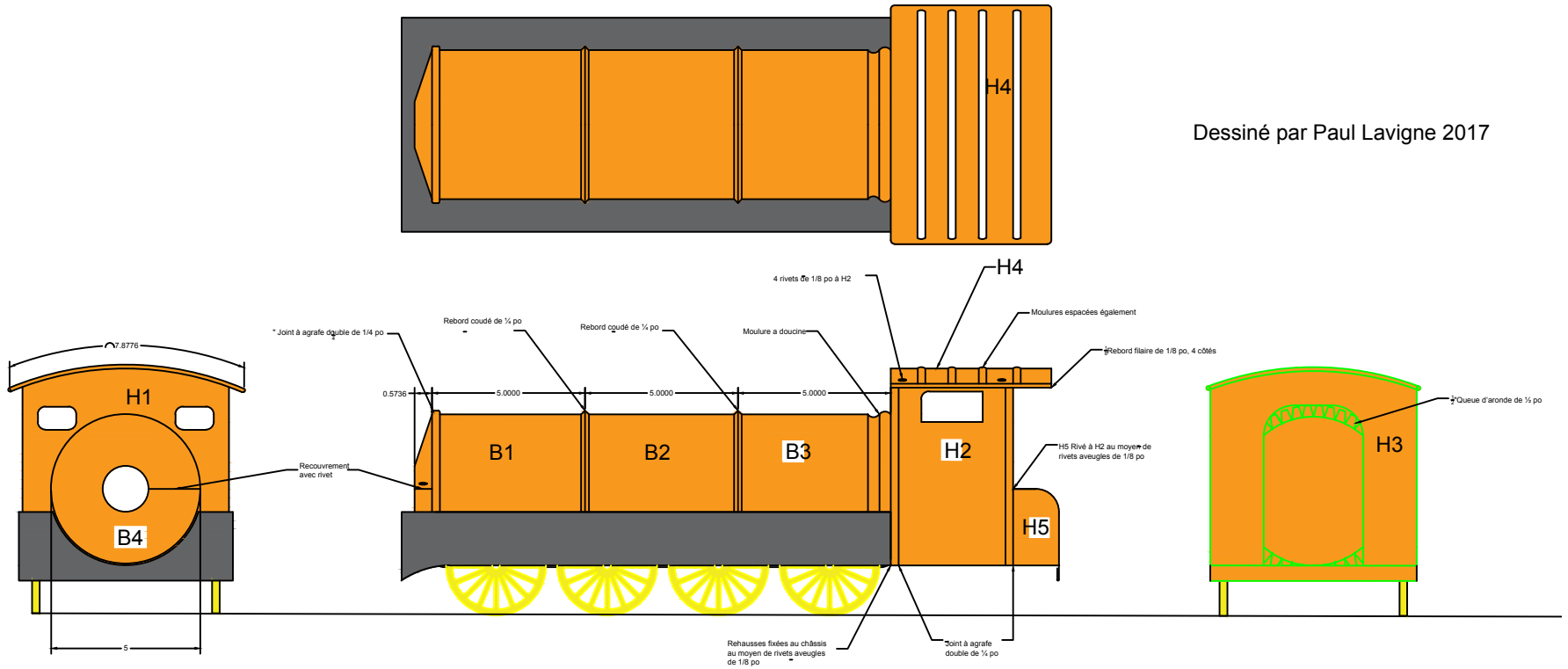

Dessiné par Paul Lavigne 2017



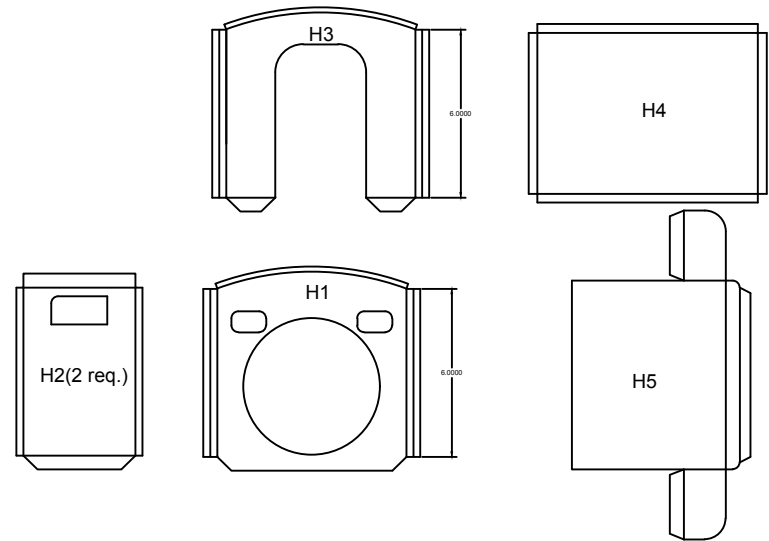
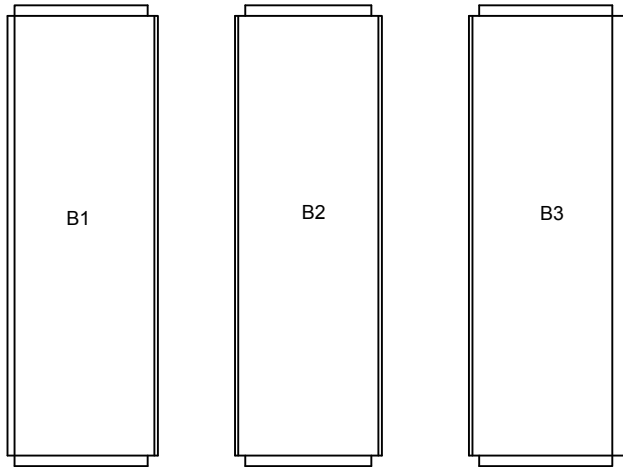
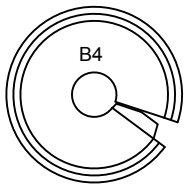
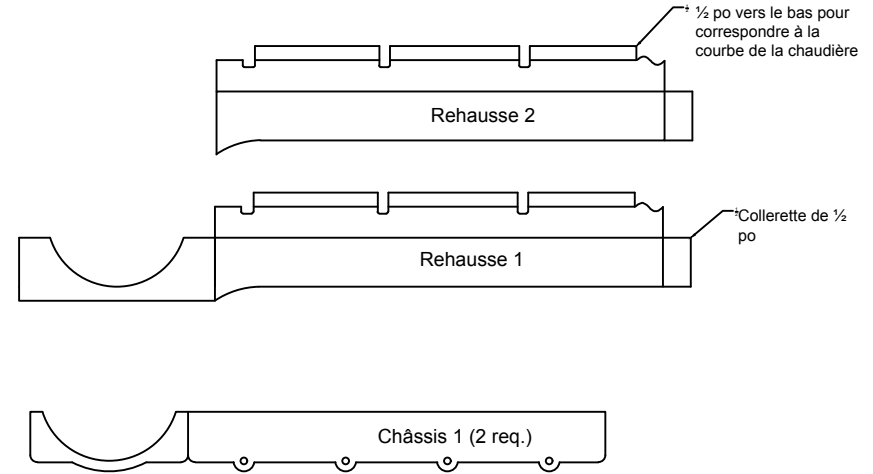
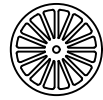

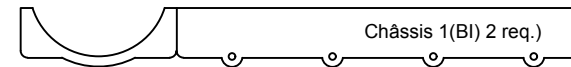
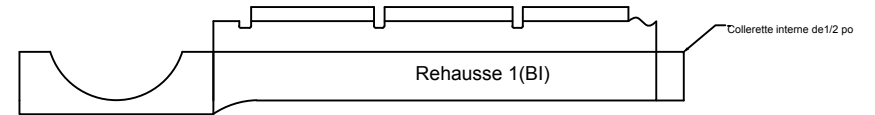
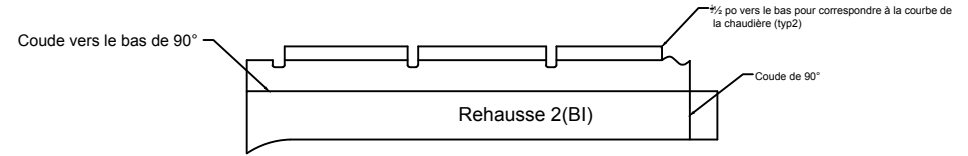

Tolérance du joint à agrafe double de 1/4 po de la partie mâle

Tolérance du joint à agrafe double de 1/4 po de la partie femelle

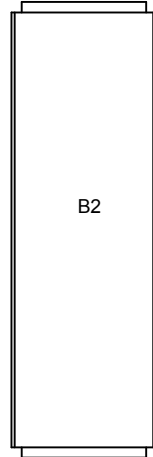
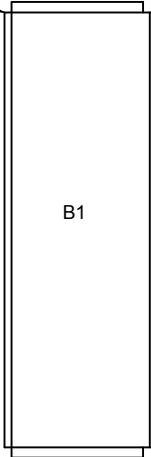
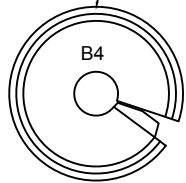

Joint rainuré de 1/4 po (typ)

Queue d'aronde de 1/2 po

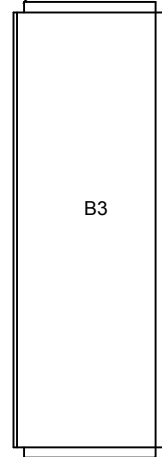

Joint à agrafe double
Partie femelle

Rebord ébavuré de 3/16 po

6.0000

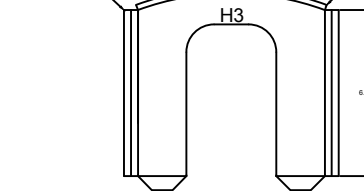

Rebord filaire de 1/8 po

H4

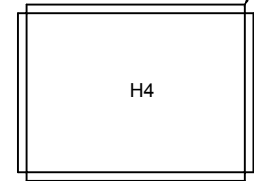

Male portion double seam allowance

Flange in to match roof curve

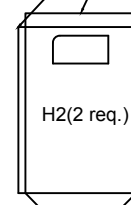

Tolérance du joint à agrafe double de 1/4 po
Partie femelle

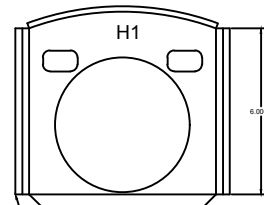

Collerette interne de 1/2 po à 90°

6.0000

