



2018

SCNC

SKILLS CANADA
NATIONAL COMPETITION

OCMT

OLYMPIADES CANADIENNES
DES MÉTIERS ET
DES TECHNOLOGIES

Skills Compétences
Canada
Edmonton2018

TEST PROJECT / PROJET D'ÉPREUVE

ROBOTICS ROBOTIQUE

SECONDARY /
NIVEAU SECONDAIRE



Pipeline

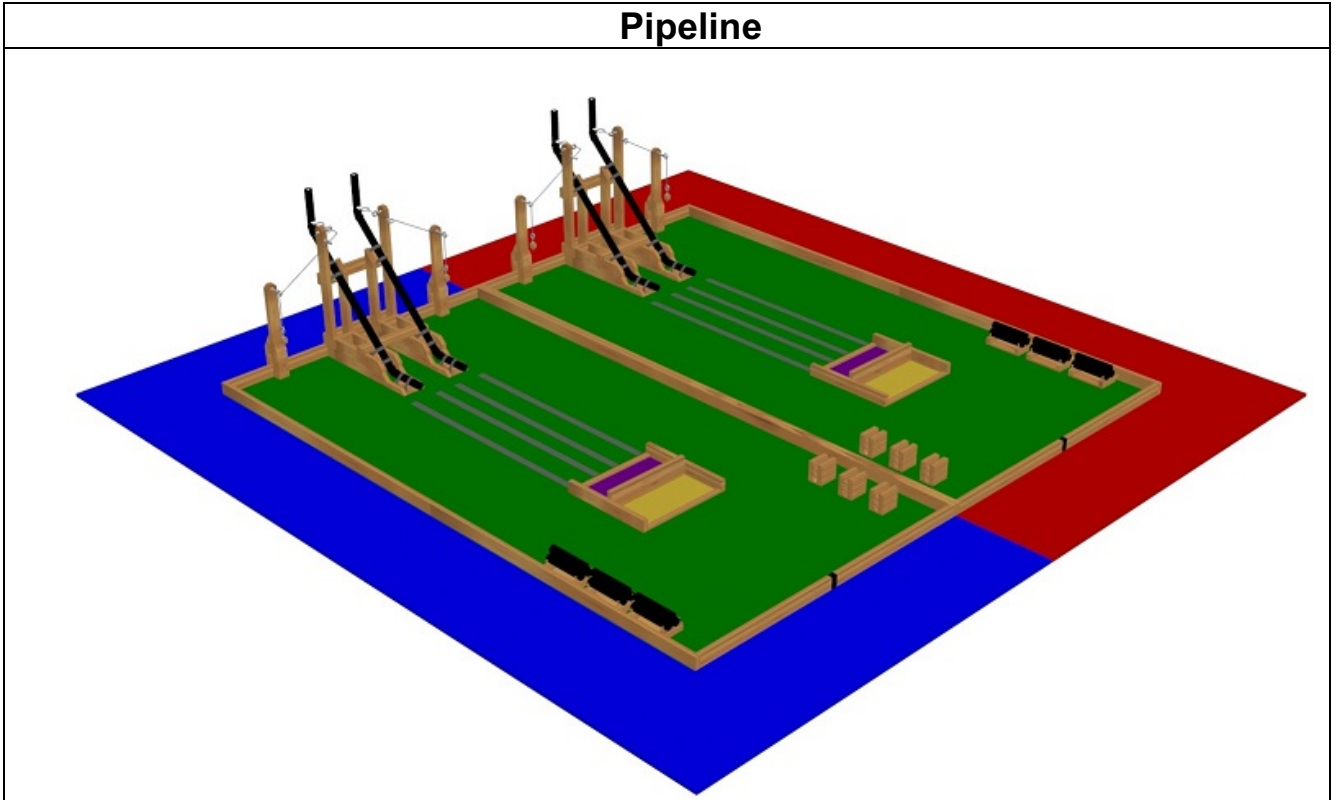

DOCUMENT USE

Table of Contents

1. Definition of terms referenced in this document	4
2. The Pipeline Teleoperation Game Overview	4
3. Pit Area and Court Access	9
4. Tournament Play	10
5. Court Layout	11
6. The Robot(s)	12
7. Start of the Game Robot Status	12
8. Overall Team Robot Entry Size	12
9. Power Sources / Management	13
10. Non-Electrical (Battery) Energy Sources	14
11. Recommended Robot Controllers	14
12. Pit Area	14
13. Overall Court Description:	15
14. Pre-inspection for Compliance with Safety and Design Rules	16
15. Autonomous Competition Overview:	17
16. Sensor Usage	17
17. Limits	18
18. Mechanical Parts	18
19. Autonomous Competition Participation Format and Scoring	18

1. Definition of terms referenced in this document

- 1.1. Tele-Operated Robot Elements are elements under the direct/active control of competitors during game play through the use of one or two radios/game controllers held by the courtside competitors
- 1.2. Mobile Independent Autonomous Mobile Robot Elements are elements that at the start of a game have a competitor pressing their start button or enter on a computer keyboard as the only competitor to Independent Autonomous Mobile Robot Element communication during the entire game.
- 1.3. Stationary Independent Autonomous Elements are elements that have their power on at the start of games but have no direct contact with a competitor during game play. These units may interact with the team's tele-operated mobile robot with the actions of the tele-operated mobile robot triggering an active response by the Independent Autonomous Element which may be managed either by a mechanical based system (eg. A series of limit switches / no programmed elements) or a pre-programmed system (eg. Managed by an Arduino or other microprocessor) internal to the Independent Autonomous Element.

2. The Pipeline Teleoperation Game Overview

The core game situation requires a Robot or Robots to build a pair of Pipelines to deliver the oil (One Inch Ball Bearings) through these Pipelines to the Refinery. In the event of a spill the Robots will be required to clean up the spill by delivering the Oil (Bearings) to a Designated Hazardous Waste Containment Site.

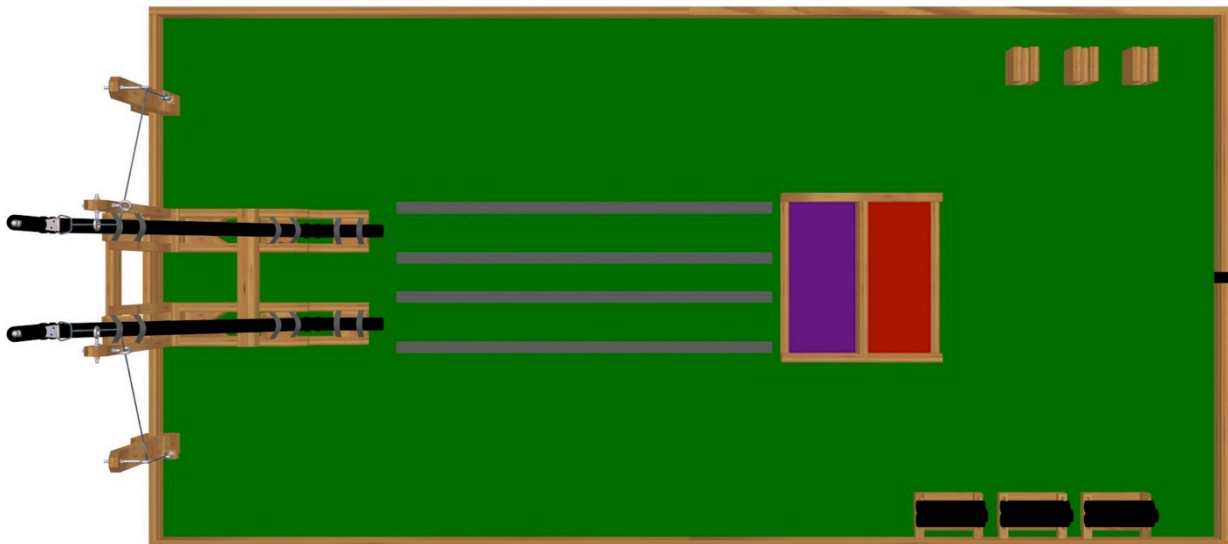

Each Team's Exclusive Use Area is approximately 8 ft. by 16 ft.



One Team's 3 Cradle Stacks

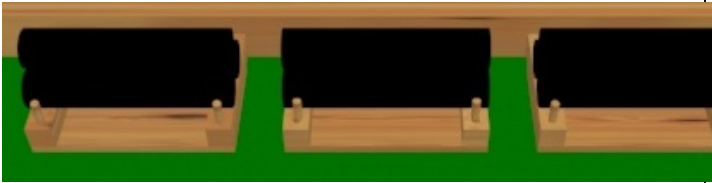

One Team's 3 Pipe Racks



One Team's 2 Oil Wells

Each Team's Exclusive Use Space has:







- 9 Pipe Cradles 6.0 by 4.5 by 2.0 in.
- 9 Pipes: 12 in. long and 1.5 in. Inside Dia.
- The Pipes are stacked in fixed position Racks.
- The Pipe Cradles are in stacks of three.
- Each Team has 2 Oil Wells with 10 One Inch Dia. Ball Bearings (Oil) in each Well

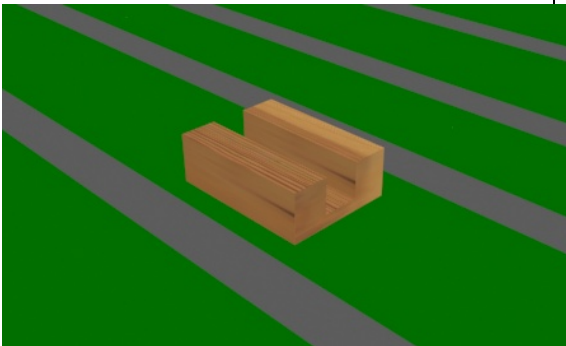

DOCUMENT USE

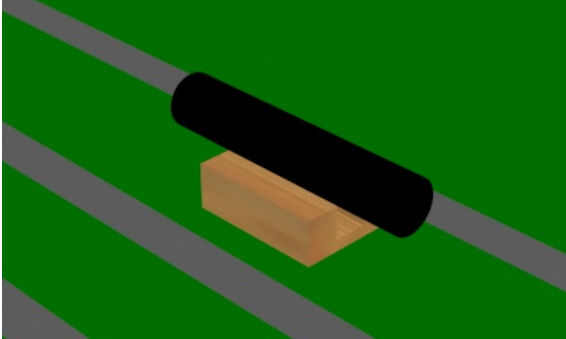

Each Team has 2 Pipeline Pathways defined by the Tape Lines shown above. A Refinery destination for the Oil Delivery (Purple Area above). A Hazardous Materials Containment Area destination for Spilled oil (Red Area above).

	
<p>Cradles must be positioned completely between the Pipeline Pathway Tape Lines to be awarded a point.</p>	<p>The Inside Edge of the Pipeline Pathway Tape Lines establishes a Vertical Plane. Cradles breaking this plane will NOT be awarded any points.</p>
	
<p>Cradles standing On End or Upside Down will NOT be awarded points.</p>	
	<p>If a stack of Cradles is correctly positioned between the Pipeline Pathway Tape Lines a Point will be awarded for ONLY the Bottom Cradle.</p>
	<p>Pipes must be held above the court floor to be awarded points.</p>
<p>One Cradle and Two Pipe Points Awarded</p>	<p style="text-align: right;">  DOCUMENT USE </p>

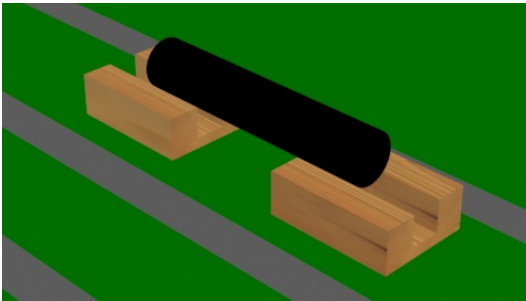

One Point Awarded

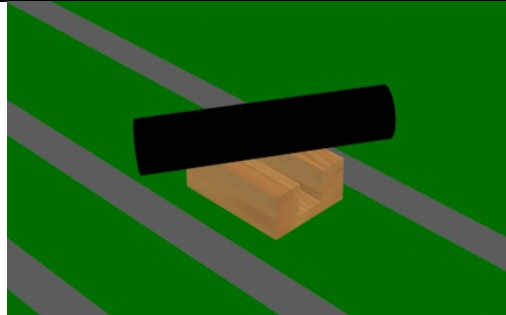

Pipe Points will be awarded independent of whether or not the Pipe is breaking the Tape Line Vertical Plane

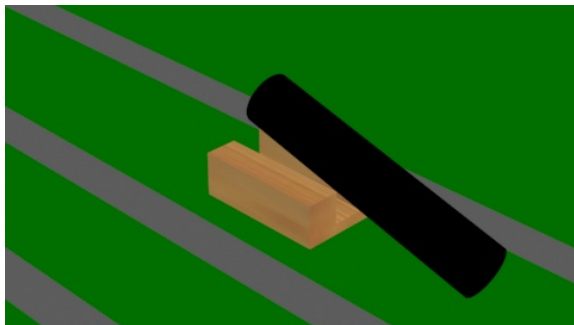

NO Point Awarded when the pipe is touching the court floor.

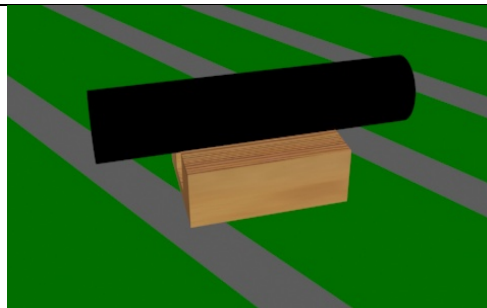

When a Cradle is in a No Point Awarded Position then No Point will be awarded for a Pipe supported by that Cradle.

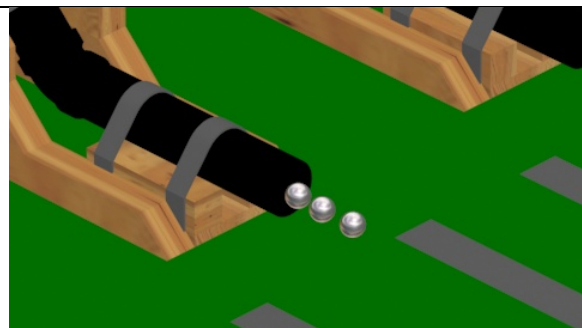

Any bearings that are spilled from the oil well must be allowed to touch the ground. They **cannot** be collected directly from the oil well pipe.

Any bearing in the open court can be collected and put in the Hazardous Material Containment Area.

Scoring Summary (scoring will be done at the end of the 4 min. match):

- a) **1 Point** for **each** Pipe Cradle placed between the Tape Guidelines,
- b) **2 Points** for each Pipe successfully placed on a cradle, Note: MUST be placed on a scored cradle
- c) **2 points** for each bearing delivered into the refinery,
Note: Bearings MUST be delivered into the Refinery through a completed pipeline
- d) **1 point** each for each bearing placed in the Hazardous Material Waste area.
- e) **MINUS 1 point** for any bearing left on the floor
- f) **0 points** for Bearings in the possession of the robot (off the floor) at the end of the game
- g) A **Bonus point** will be awarded to the team that delivers all of the Oil

(Bearings) through the pipelines into the Refinery first.

2018 Skills Canada - Edmonton Robotics Pipeline Game Score Sheet						
Game # Court A Team Name	Total Number of Pipe Cradles Positioned Correctly Value: One Point Each	Total Number of Pipes Positioned Correctly Value: Two Points Each	Total Number of 'Barrels of Oil' (Bearings) Delivered into the Refinery Value: Two Points Each	Total Number of 'Barrels of Oil' (Bearings) Delivered into the Hazardous Material Containment Area Value: One Point Each	Total Number of 'Barrels of Oil' (Bearings) Remaining on the Open Court Floor Value: MINUS One Point Each	Total Game Score
	Team Signature:					
Game # Court B Team Name	Total Number of Pipe Cradles Positioned Correctly Value: One Point Each	Total Number of Pipes Positioned Correctly Value: Two Points Each	Total Number of 'Barrels of Oil' (Bearings) Delivered into the Refinery Value: Two Points Each	Total Number of 'Barrels of Oil' (Bearings) Delivered into the Hazardous Material Containment Area Value: One Point Each	Total Number of 'Barrels of Oil' (Bearings) Remaining on the Open Court Floor Value: MINUS One Point Each	Total Game Score
	Team Signature:					

Note: Competitors will participate in BOTH the Teleoperation Pipeline Game and the Built On-site Autonomous Robot Tasks during BOTH Competition Days.
Teleoperation Pipeline Game Description

- Games will involve Two Teams at a time.
- Both Competitors are allowed unrestricted movement around the perimeter of their Team's Assigned Court Area.
- Teams can utilize a Maximum of 2 Tele-operated Robots.
- Teams may also have Independent Autonomous Elements as part of their entry.
- Teams will NOT be in possession of a part at the Start of a Game.
- Each Team's robot CAN be in possession of more than one Cradle or Pipe at any time.
- Teams must build their Pipelines using only the provided Cradles and Pipes.
- Teams cannot use any mechanical devices or tape elements to secure Pipes or Cradles in place
- When Teams release the Oil (Bearings) from a Well they must ensure that ALL Elements of their Robots are well away from the Pipeline to ensure that no element of their robot's (Frames / Wheels / Object Management Systems) are in a position to prevent / hold the Pipeline from breaking apart.

3. Pit Area and Court Access

A pit area is provided so that students may make repairs and improvements to their robots between games. (Note: Teachers are not permitted in the pit area once the competition has started).

Teams MUST bring their Robots into the skill area at Orientation. Teams are NOT allowed to remove their robots from the skill area during the over-night periods between Orientation Day, Competition Day 1, and Competition Day 2 of the contest. Laptops may be removed overnight by competitors.

The pit area and contest court may be available to teams to work or practice during lunch breaks if a NTC committee member is present.

4. Tournament Play

- 4.1. Pipeline Game Tournament will be based on an 'Unseeded Tournament Format'.
- 4.2. Pipeline Tournament Standing will be based on total score in all games played by each team.
- 4.3. Teams will play in an equal number of Tournament Games.
- 4.4. If Time Permits, Teams will participate in an equal number of games against each opponent Team.
- 4.5. In the event of a Tournament Standing Tie a special 2 minute Tie Breaking Game will be played.
- 4.6. Pipeline Playoffs will follow a 'Seeded Tournament Format'.
- 4.7. Pipeline Playoffs will be a double knockout format.
- 4.8. Tournament and playoff games will last 4 minutes
- 4.9. The amount of time between games will be determined by the number of participants. This information will be provided to teams at the start of the tournament.
- 4.10. Between tournament games, battery changes and repairs to robots may be completed at the team's assigned Pit Area Worktable.
- 4.11. During the competition, protective safety glasses is expected to be worn while performing material removal tasks (cutting, drilling, etc.).
- 4.12. During game play, referees will have ultimate authority over game rulings, and will have full authority over team conduct in the court area.
- 4.13. Damaging the court area is prohibited. If a robot's design causes damage to the court elements, then it will not be allowed to compete until it can operate without causing damage. Games missed due to this situation will be forfeited. NOTE: Damage is considered to be BREAKING court components. Robots bumping into court components and causing them to shift position without breaking any court element will NOT be considered to be damaging the court. It is expected that all court components will be fixed firmly in place so that the court is a Neutral Factor in the competition.
- 4.14. Games will start on time. Teams are responsible to know when their games are scheduled. Teams arriving late will be allowed to use the remainder of the time in the game. Competitors cannot enter onto the court surface or make adjustments to their robot during a game.
- 4.15. If a robot is mal-functioning and represents a hazard to participants, other robots or itself in the opinion of the Referee, then, the referee may stop the clock, and may authorize the shutting off of the robot during a game. Disabled robots or parts of robots not generating any safety concerns will be left on the court until the game time expires.
- 4.16. It is a Team Decision what roles team members will fill. Drivers are the competitors holding the robot controller and asserting direct control over a Tele-operated robot.
- 4.17. The Spotter would be the competitor providing navigational guidance to the driver.
- 4.18. Competitors may change roles while a game is in progress.
- 4.19. Competitors (Driver/s and/or Spotters) can move freely in their Assigned Courtside Team Area throughout the game.

- 4.20. Competitors may **not** enter an opponent team's Assigned Courtside Team Area at any time during game play.
- 4.21. At the start of a game, robots are expected to be in their Designated Starting Positions.
- 4.22. Robots arriving AFTER a game has started will be allowed to enter the game and use the Time remaining in the 4 min. game.
- 4.23. Robots must not leave the contest court at any time during a game.
- 4.24. It will be a referee's ruling that decides if an 'End of the Game piece delivery took place before or after the game-ending buzzer sounded.
- 4.25. If a pipe, cradle or bearing falls out of the court, it may not be retrieved and will be out of limits of play.
- 4.26. Robots must build their pipeline using ONLY the provided Pipes and Cradles.
- 4.27. Robots cannot use tape or mechanical devices to hold pipeline elements together.
- 4.28. Robots must be positioned outside the Pipeline Tape Pathway, when the Oil is released from the well, to ensure no part of a Robot (wheels / frame / object management system) is providing support for or holding the pipeline together.
- 4.29. Scoring will take place after the End of the Game Buzzer
- 4.30. No aerial (flying) robots are allowed.

5. Court Layout

Please note: Although great pains will be made to keep the court in compliance with the drawings, some inaccuracies in construction may occur. **Please make your robot designs allowing for a possible 1/2 inch tolerance.**

The primary court items that have a direct bearing on robot design are:

- The open court surface will consist of the good side of Plywood Sheets **OR** the facility floor **OR** the smooth side of Masonite Sheeting.

Detailed court information has been included in the Appendix Section of this document.

6. The Robot(s)

6.1. Restrictions

All tele-operated Robots must **pass** a pre-competition inspection for compliance with the safety and design rules before they will be allowed to participate in tournament games.

Note: Robots must remain in compliance with these rules throughout the competition. If teams fall out of compliance with these rules then they will not be permitted to compete and will forfeit all of their scheduled games until they have corrected the problem.

7. Start of the Game Robot Status

When a robot's main power is turned on prior to the start of a game the robot must be in an overall 'Idle State' and the following conditions must exist:

- Robots must be stationary
- Robots must be in their designated Starting Location.
- If Team Entries involve multiple Robots / Mechanisms then all of them must be placed in the designated starting location and must be positioned to not exceed the allowed total 4 cu ft. volume per Team.
- All systems may be ON.
- Air System Circuits may be fully charged to 100 PSI and their compressors can be ON.

8. Overall Team Robot Entry Size

- 8.1. Complete Team Entries must not exceed an overall size of **4 cubic feet** (6,912 cubic inches) at the start of each game.
- 8.2. Team Entries may expand to a larger size once a game has started.
- 8.3. Overall Team Entry Size will be calculated by using the maximum single dimension in each category (Length / Width / Height) of the Complete Team Entry not average dimensions.
- 8.4. This overall size maximum will allow Team Entries to be any variation / combination of elements that does not exceed **6,912** cubic inches, using the following formula:
Volume = Length x Width x Height

9. Power Sources / Management

9.1. The total voltage in any individual circuit **cannot** exceed **24 Volts**.

9.2. The **maximum continuous** power rating allowed in any circuit branch is **240 W**, which will be limited by voltage and fuse selection. A larger main fuse can be used to provide protection for motor controllers. To calculate power in any given circuit, use the following formula: Power (Watts) = Voltage (Volts) x Current (Amps)

Acceptable Circuit Protection: (ESC is NOT protected by fuse)

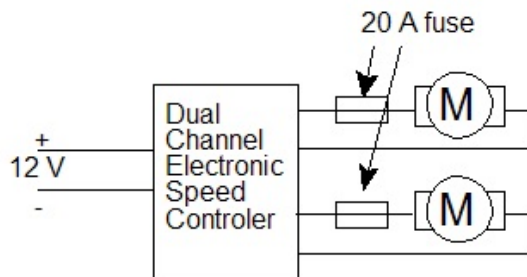

Recommended Circuit Protection: (ESC IS protected by fuse)

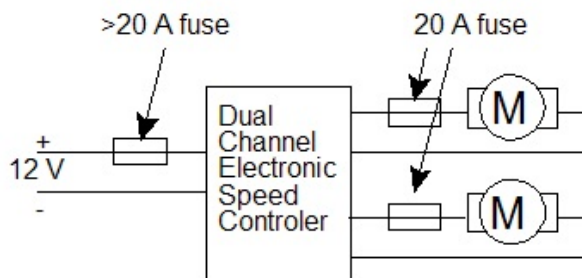

DOCUMENT USE

9.3. Teams are reminded that it is the purpose of a fuse to protect the students themselves and the equipment in their circuits. Teams must develop circuit diagrams, and calculate the appropriate values for all circuits on their robot. Teams must submit a wiring diagram of their robot's circuits.

9.4. Each current branch path from the battery must include either an **in-line fuse**, **resettable fuse**, **circuit breaker**, or be connected to a dedicated fuse in a rack.

9.5. Batteries must be complete sealed commercial battery packs.

9.6. ALL Robots must be able to be turned off with a single motion.

9.7. Robot Controller receivers may be in an independent circuit.

9.8. No explosive materials of any kind may be used (ether, gunpowder, acetylene etc.)

10. Non-Electrical (Battery) Energy Sources

- 10.1. Pressure based energy sources (air or other) may be pre-charged to a maximum of 100-PSI pressure in their reservoirs (cylinders) at the start of each game.
- 10.2. Air pressure systems using Competitor-made or modified air pressure hardware are **NOT** permitted.
- 10.3. All pressurized tanks on robots must have a pressure gauge to indicate the stored pressure and a form of automatic overpressure safety relief system.
- 10.4. The pressure tanks and related gauges / controls must be shielded from damage due to collisions or flying target objects.
- 10.5. The stored pressure in the tank must not exceed a maximum of 100 PSI at any time.
- 10.6. Tension-based energy sources (elastics, springs or other) may be in either a relaxed at rest state or in a tense / compressed state at the start of each game.
- 10.7. Laser devices are prohibited.

11. Recommended Robot Controllers

- 11.1. It is recommended (not required) that all teams use 2.4 GHz “non-crystal” control systems on Tele-operated Robots.
- 11.2. Teams are allowed the use of an unlimited amount of channels, but only two separate tele-operated robots. Teams assume full responsibility if any interference is to occur with their respective communication systems that could render the robot(s) useless.
- 11.3. Tele-operated Robots may not transmit audio/visual information to off the robot devices. (Ex: Having a camera transmit images real time to a computer near the driver, etc.)

12. Pit Area

- 12.1. Competitors **MUST** wear safety glasses when doing fabrication work involving material removal processes (grinding / cutting).
- 12.2. Only registered robot are permitted in the contest space.
- 12.3. Designated teacher/industry team advisors are permitted in the pit area **only** to inspect the worktable setup of their team prior to the start of the tournament.
- 12.4. Designated teacher/industry team advisors are **not** allowed in the pit area during tournament play.
- 12.5. Teachers and industry advisors are not permitted to handle tools or robot parts. Students must affect all repairs and modifications on their robot.
- 12.6. Teams will be provided with a pit area workspace on a standard project table. Depending on the number of teams and availability of space, teams may have to **share** a 60 by 30 inch table.
It is required that teams fabricate a **tabletop stand** for holding their robot(s) in the pit area. This stand or these stands should hold the robot(s) securely and be capable of preventing the robot(s) from driving on or off the table in the case of either deliberate motor testing during repairs or due to random, unexpected motor activity.

13. Overall Court Description:

- 13.1. The Court Playing Surface will be a 16' by 16' square.
- 13.2. Individual Exclusive Use Team Spaces are 8' by 16' rectangles.
- 13.3. The Perimeter Court Walls will be made using 2 by 4 inch planks.
- 13.4. This wall will as a result be approximately 3.5 inches tall.
- 13.5. The court surface may vary between melamine, concrete, hardboard, or plywood.

14. Pre-inspection for Compliance with Safety and Design Rules

- Mandatory Wiring Diagram provided.
- Table Top Robot Stand
- Overall volume $\leq 4 \text{ ft}^3$ or $6,912 \text{ in}^3$
- No explosives/combustibles
- No lasers
- All batteries are sealed commercial batteries in good physical condition
- Batteries wired in series should be the same amp hour rating (ex. both 1500 mAh) and batteries in parallel are of same voltage (ex. both 12 volts).
- Batteries securely mounted
- Total voltage in any individual circuit does not exceed 24V
- No circuit **branch** exceeds 240W (Voltage x Fuse Current Rating, easily accessible)
- All circuits have a fuse or breaker (breakers must have **DC rating**) and all Fuses / Breakers must be readily accessible.
- Mandatory Pressure System Circuit Diagram provided.
- No Competitor-made or modified air pressure hardware being used.
- Only commercially manufactured Pressure Tanks (cylinders) can be used.
- Pressure indicator
- Pressure in tanks does not exceed 100 psi
- Over-pressure safety valve
- Pressure tanks and related gauges and controls are shielded from damage due to collisions
- Robot is able to be turned off with a single motion.** Radio receivers / Logic circuits may be independent of the kill switch.
- Control unit to support operator to robot communication are being used.
- Demonstration of robot functionality

Additional concerns:

--	--

Robot Evaluator Signature

Team Representative Signature



15. Autonomous Competition Overview:

- 15.1. Competitors will be provided, at no cost to the teams, with a kit distributed to them through their provincial/Territorial office.
- 15.2. The autonomous robots must be disassembled on arrival.
- 15.3. A description of the Competition Component Collection will be posted on the Skills/Compétences Canada Website.
- 15.4. Competitors will build on-site Autonomous Robots using the provided common set of components.
- 15.5. Competitors will demonstrate their robots performance in a court to be defined at the Skill area. (while melamine courts will be used)
- 15.6. At the orientation meeting, Competitors will be told the specific Robot Behaviors their Built On-Site Robots need to complete.
- 15.7. The suggested performance items listed below reflect the type of core isolated robot performance elements competitor robots will need to complete
 - Follow wall perimeter,
 - Navigate a maze,
 - Navigate around obstacles,
 - Follow a colored tape line on the floor,
 - Locate and touch an object
 - Pick up a small object and move it to a new location
- 15.8. Competitors **MUST** understand the list above represents **samples ONLY** and does not present a final or complete list of the potential robot behaviors they might be asked to create.
- 15.9. Teams need to develop an understanding of the performance capabilities of ALL components in the Competition Collection and prepare to be able to use any of these components effectively.
- 15.10. Competitors need to be prepared to go beyond the initial single stage performance requirements to multi-stage performance requirements as the culminating end of the competition experience.
- 15.11. Build On-Site Autonomous Tasks Equipment
- 15.12. Micro-Controller Usage
- 15.13. Competitors can use ANY microprocessor they want at the national competition.

16. Sensor Usage

Competitors choosing to NOT use the provided microprocessors can replace the provided sensors with sensors having comparable performance characteristics that are compatible with their alternate microprocessor. However they must comply with the overall allowed number / type of sensors listed below.

17. Limits

- 17.1. 3 distance sensors (ultrasonic or infrared...no laser sensor)
- 17.2. 3 line sensors (no arrays allowed...only individual sensors)
- 17.3. 2 continuous servos
- 17.4. 2 standard servos

18. Mechanical Parts

Competitors must work with the materials provided in the kit and not introduce any new materials or components. Cable ties and tape are the exception.

19. Autonomous Competition Participation Format and Scoring

- 19.1. Teams will have time periods where they have shared access to the various Autonomous Performance Court Environments to conduct their Task Solution / Preparation Activities
- 19.2. Teams will have a maximum of Three Marked Attempts at each of the Autonomous Performance Tasks
- 19.3. Marked Autonomous Task Attempts will be conducted on a 'By the request of the Teams Basis with a requirement that Teams complete ALL Autonomous Task Preparation Activities by an announced at the start of the competition Fixed Time: Example: All Autonomous Task Preparation Activities must end by 3:45 PM on Competition Day 2.
- 19.4. Team Marks will be based on their Best Performance out of their three attempts.

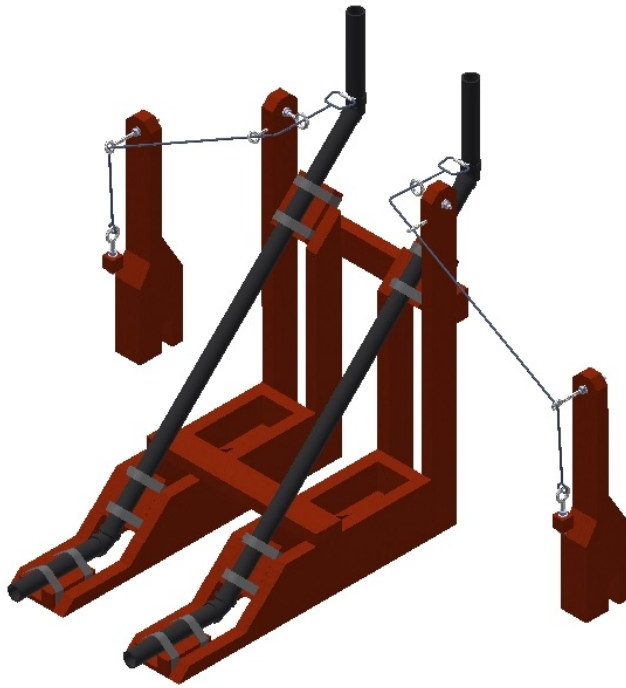

One Team's Exclusive Use Oil Wells

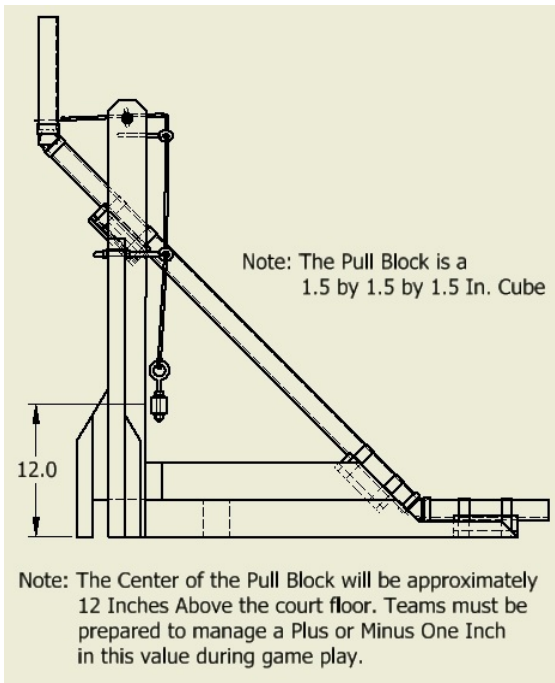

Oil Well Pull Block



DOCUMENT USE

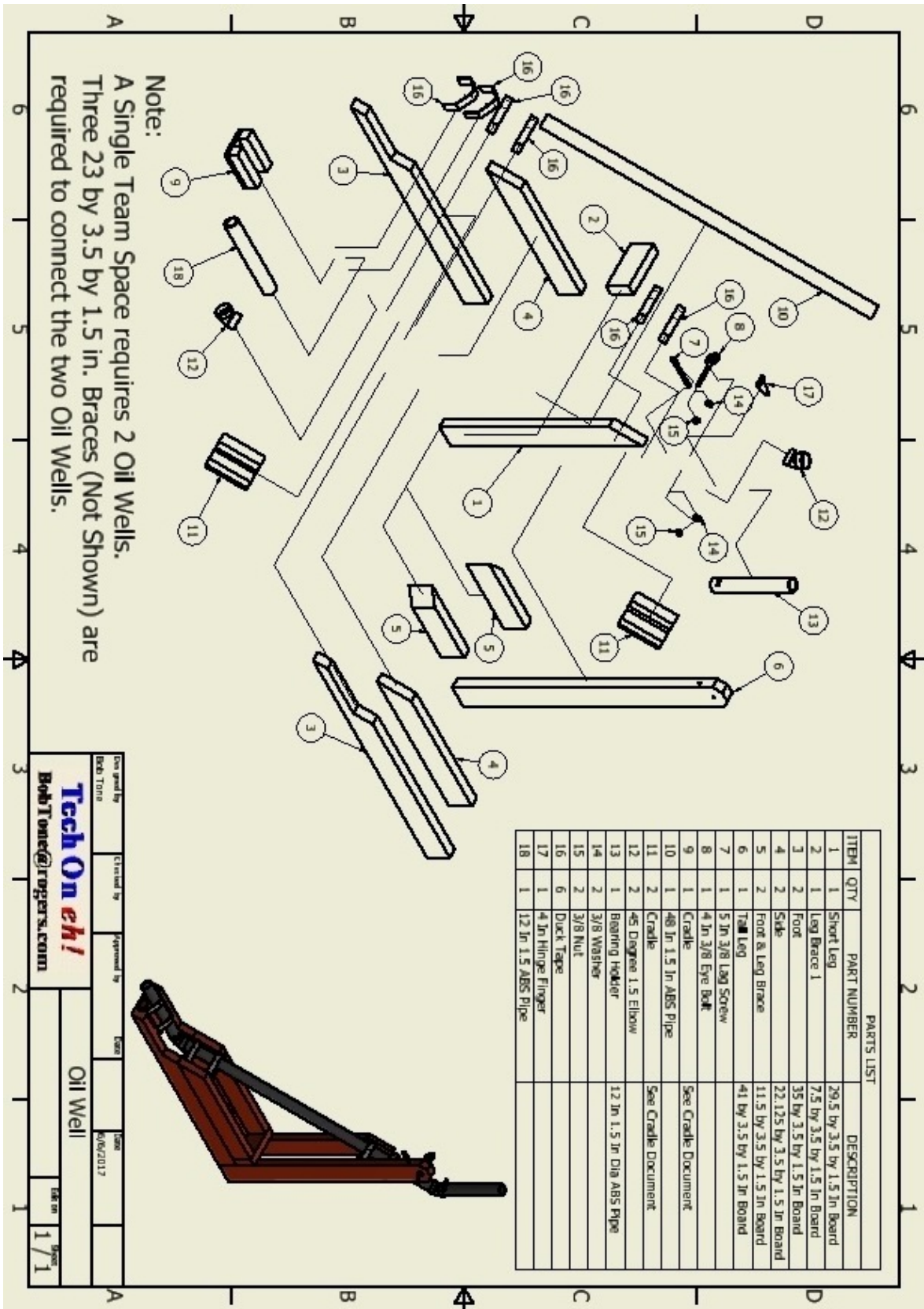

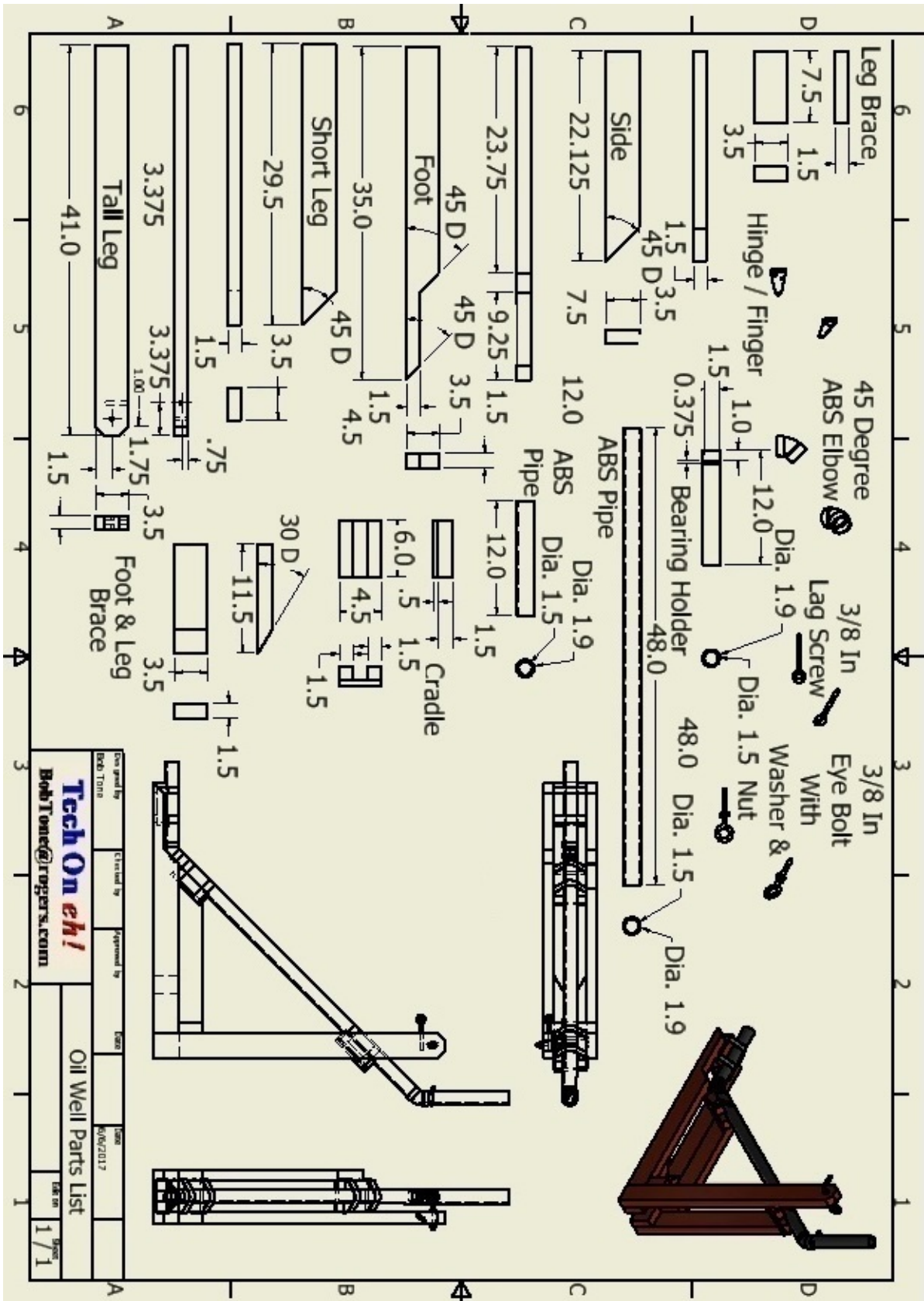

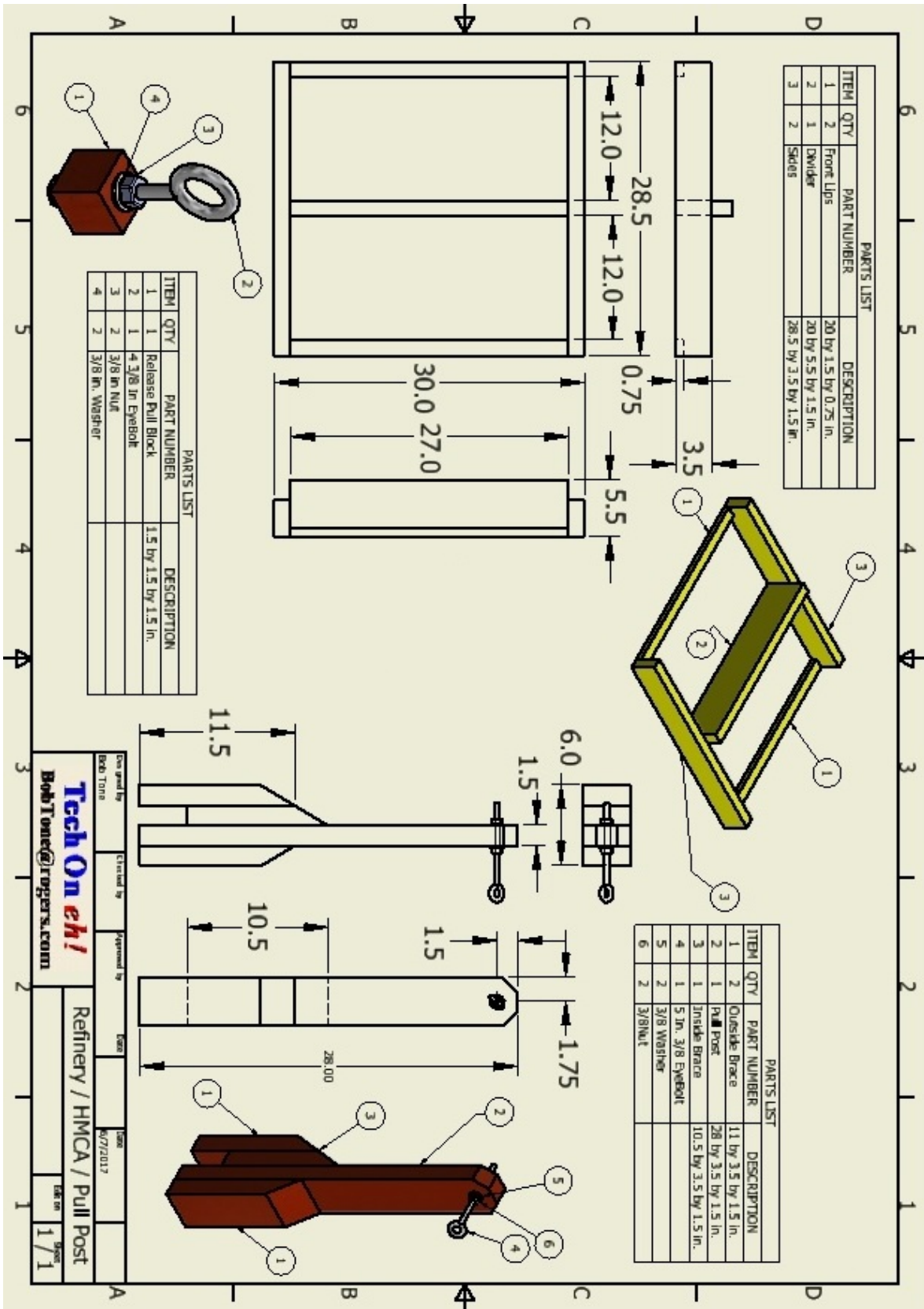

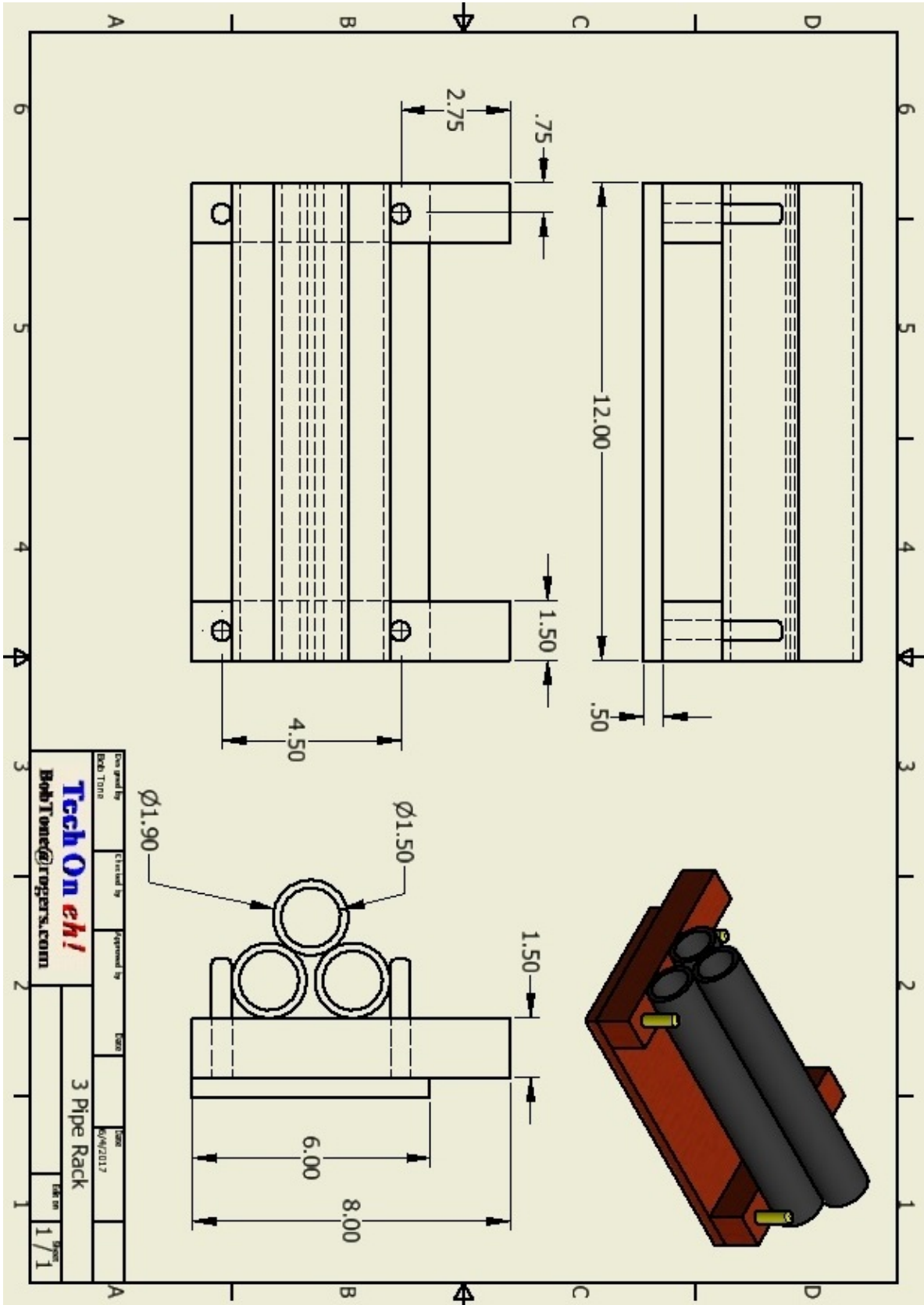

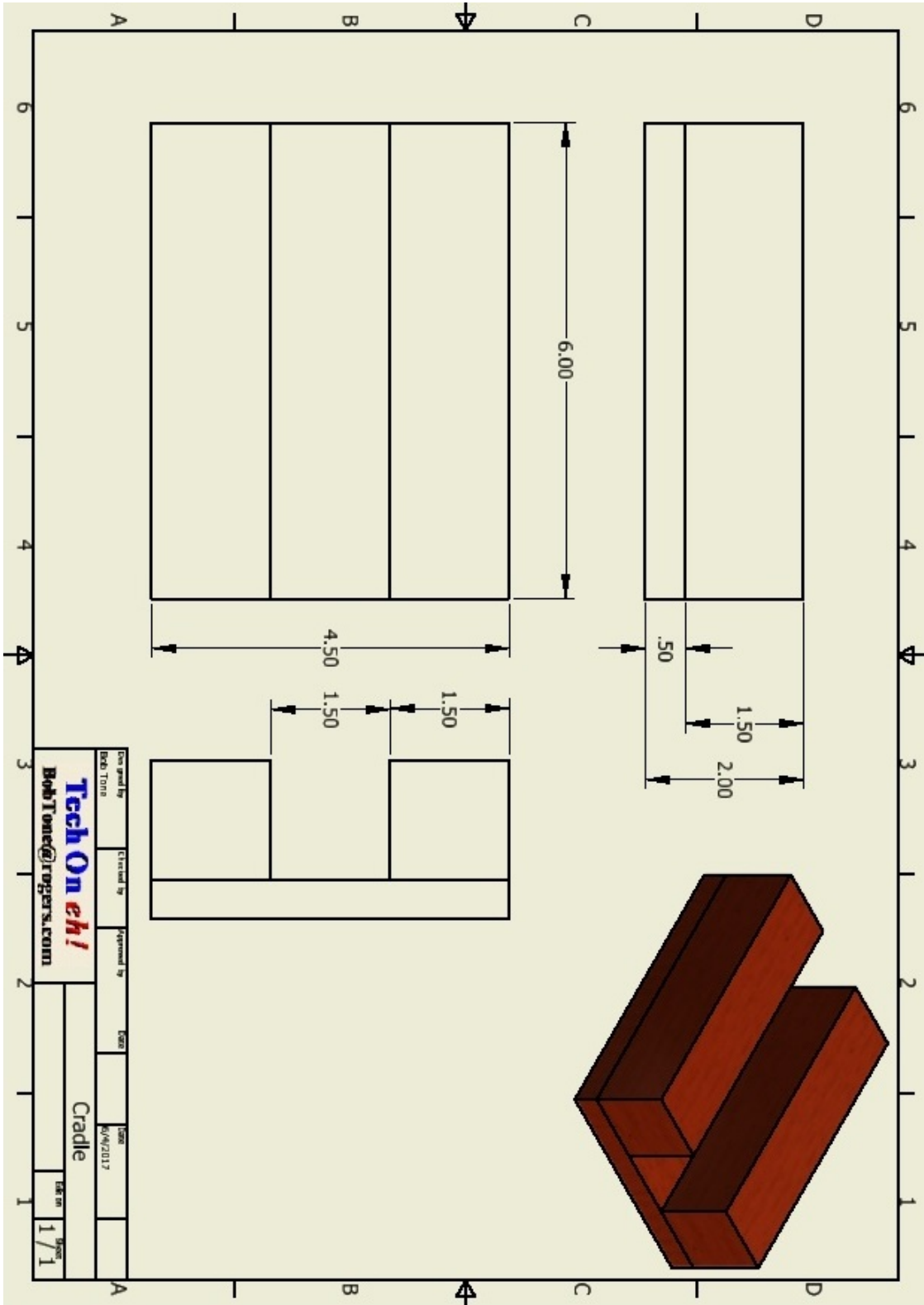

DOCUMENT USE