

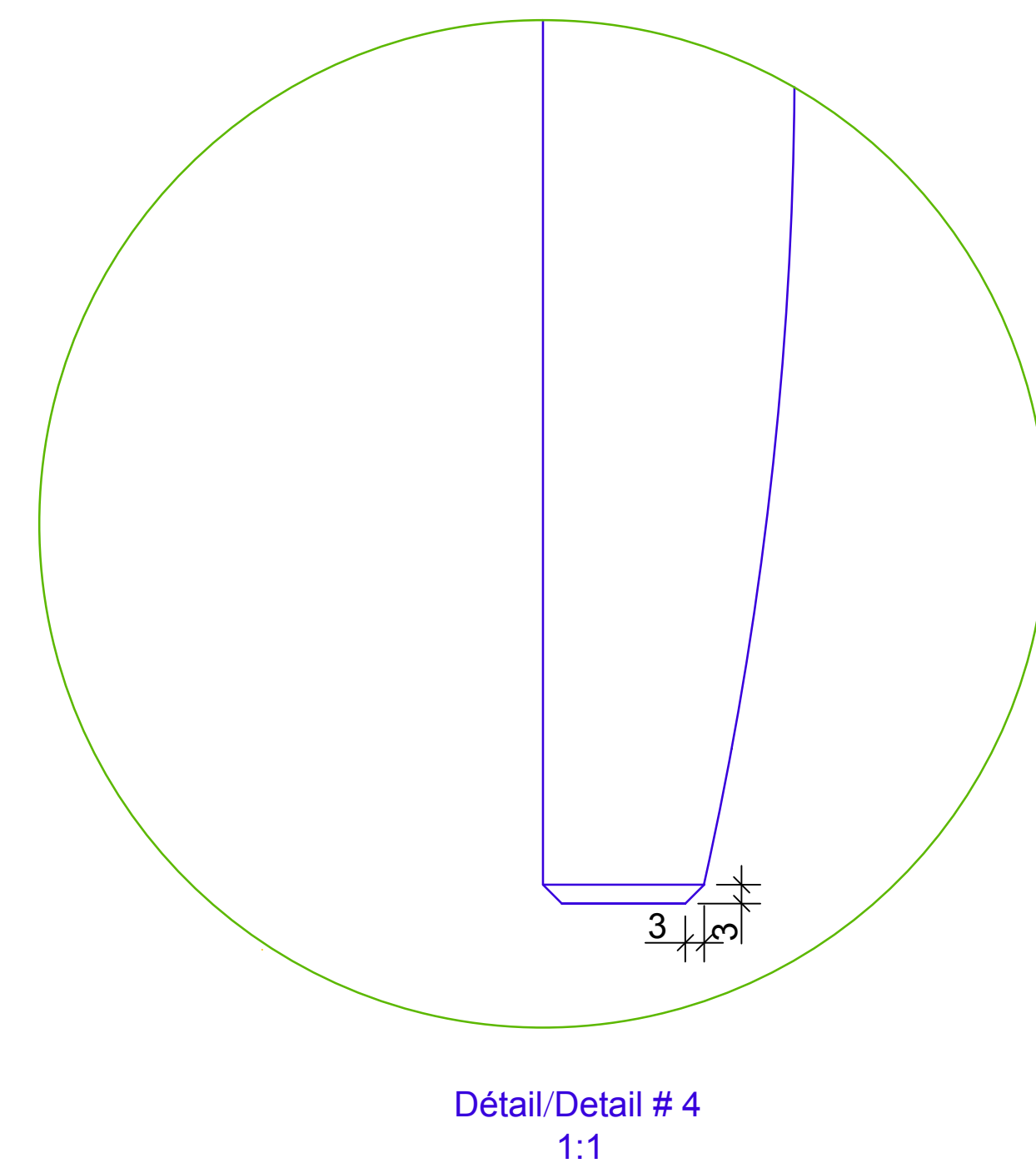

TEST PROJECT / PROJET D'ÉPREUVE

# CABINETMAKING EBENISTERIE

SECONDARY AND POST-SECONDARY /  
NIVEAU SECONDAIRE ET POSTSECONDAIRE

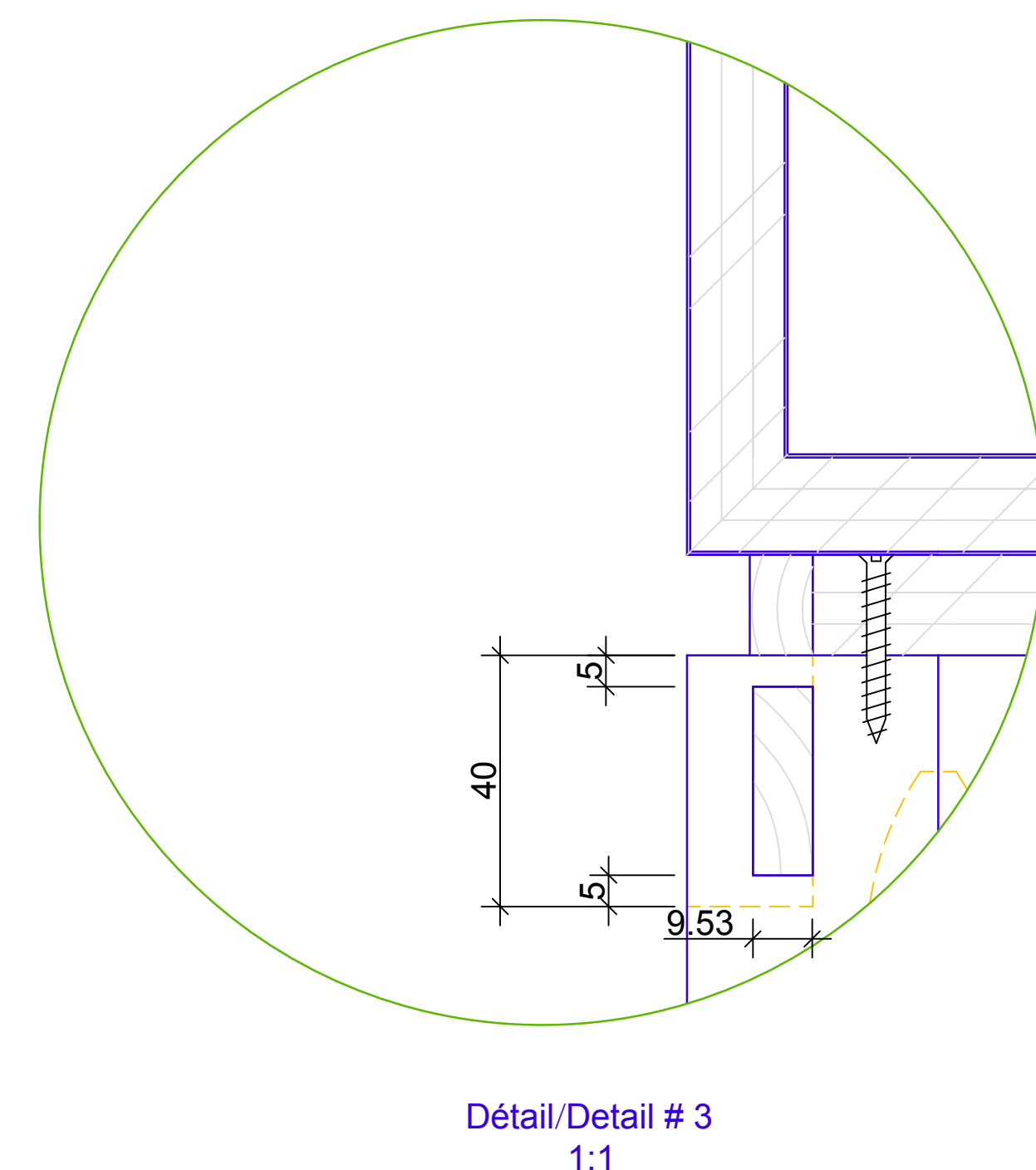
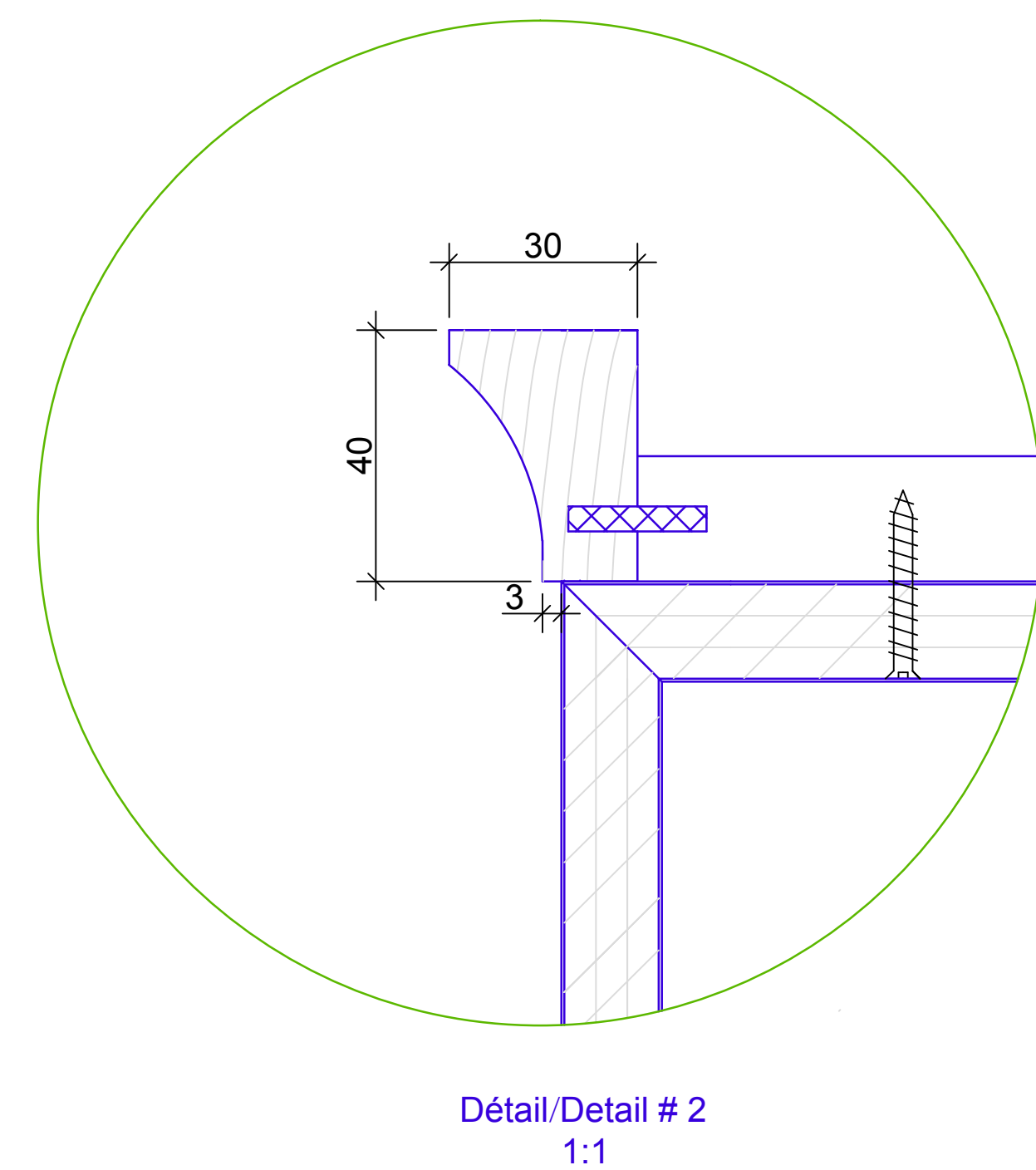
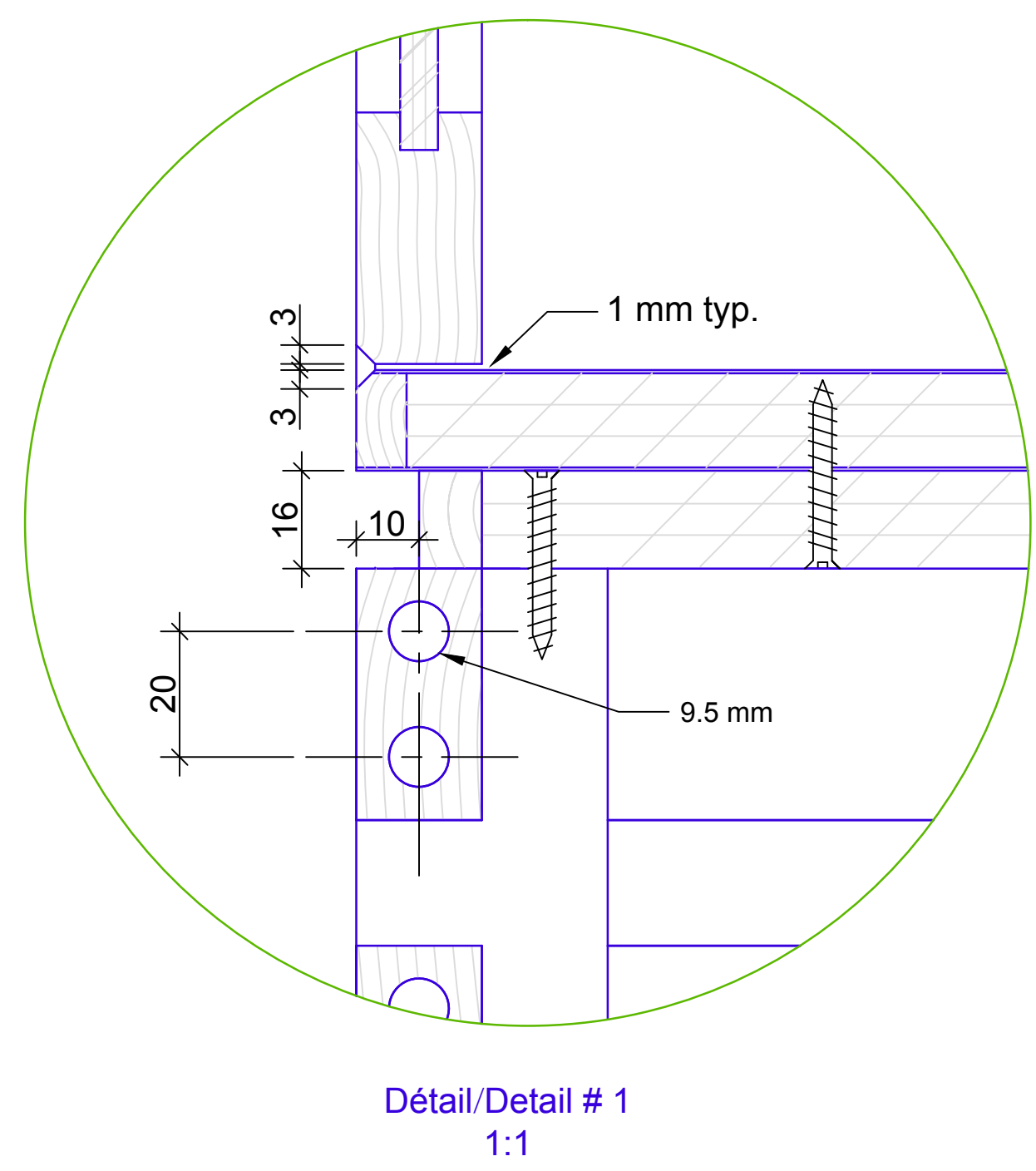
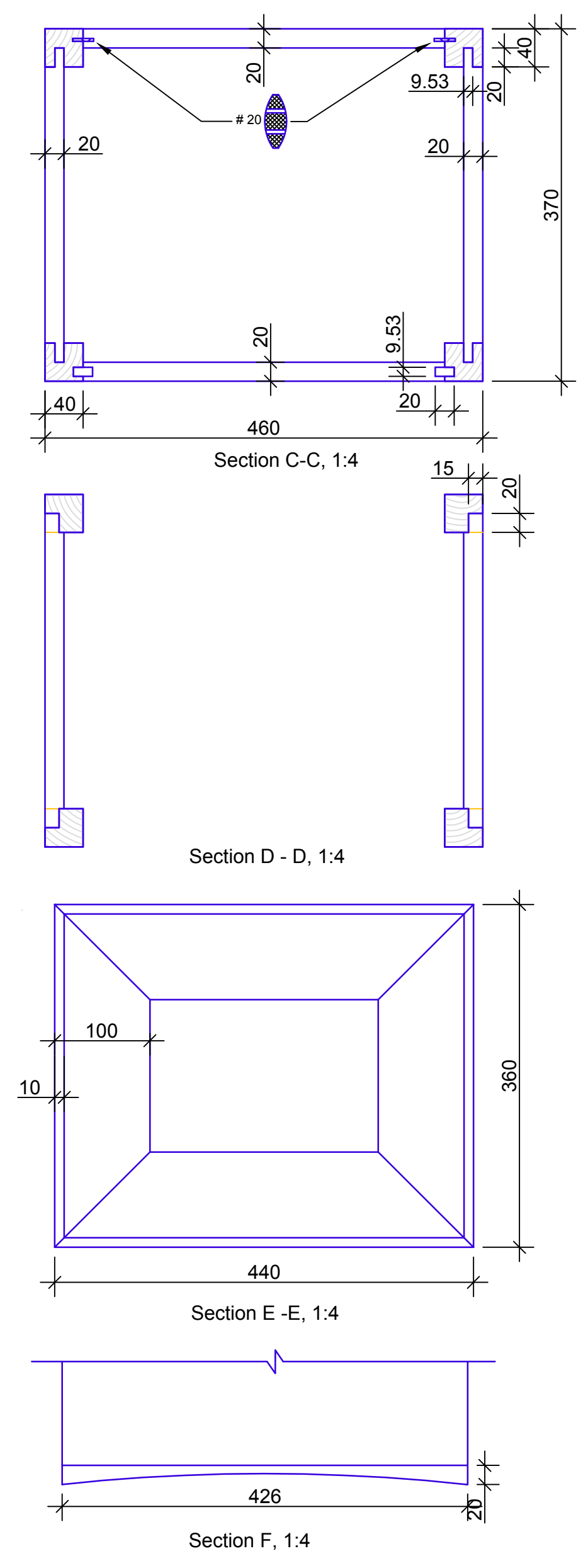
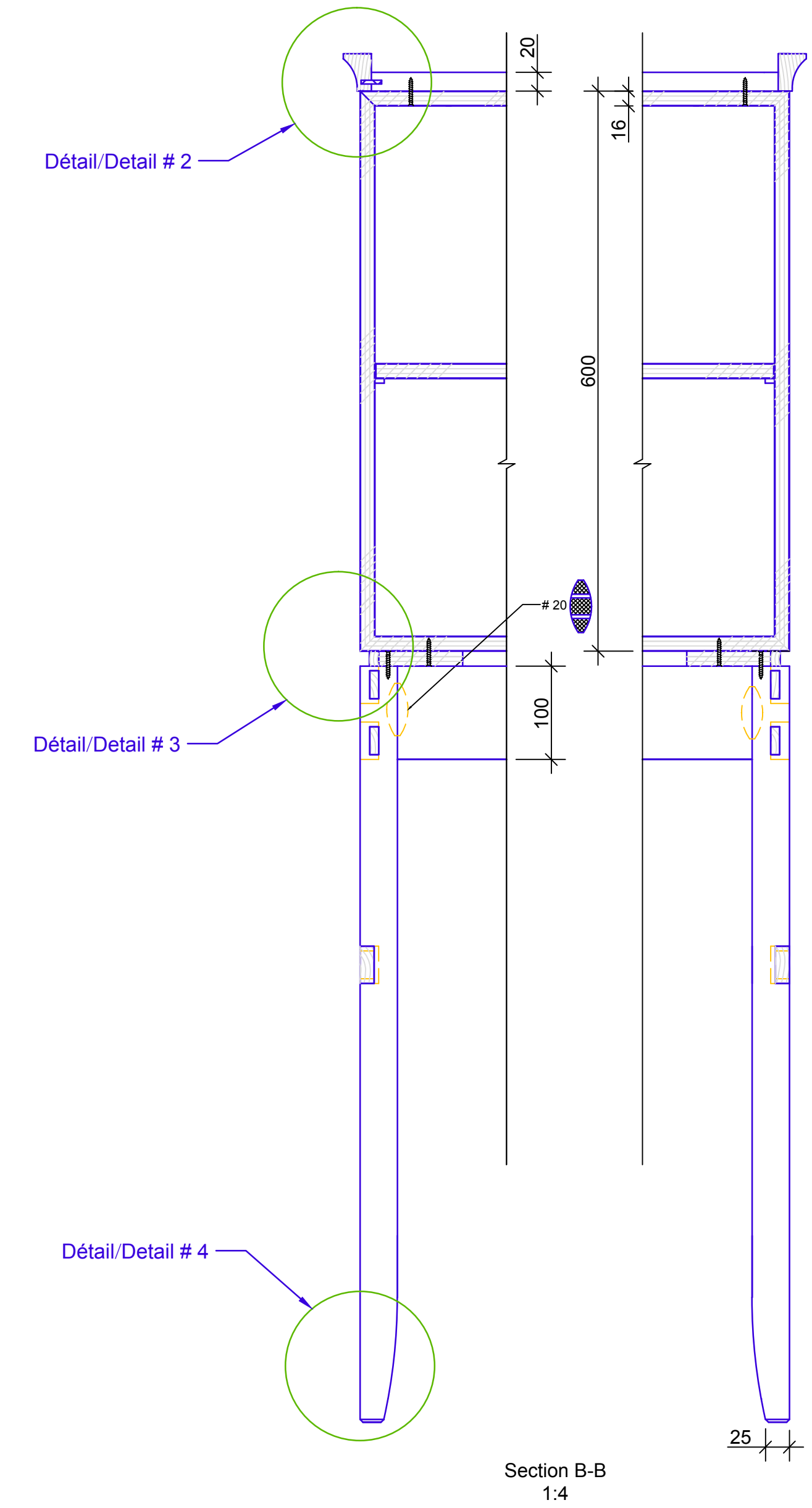
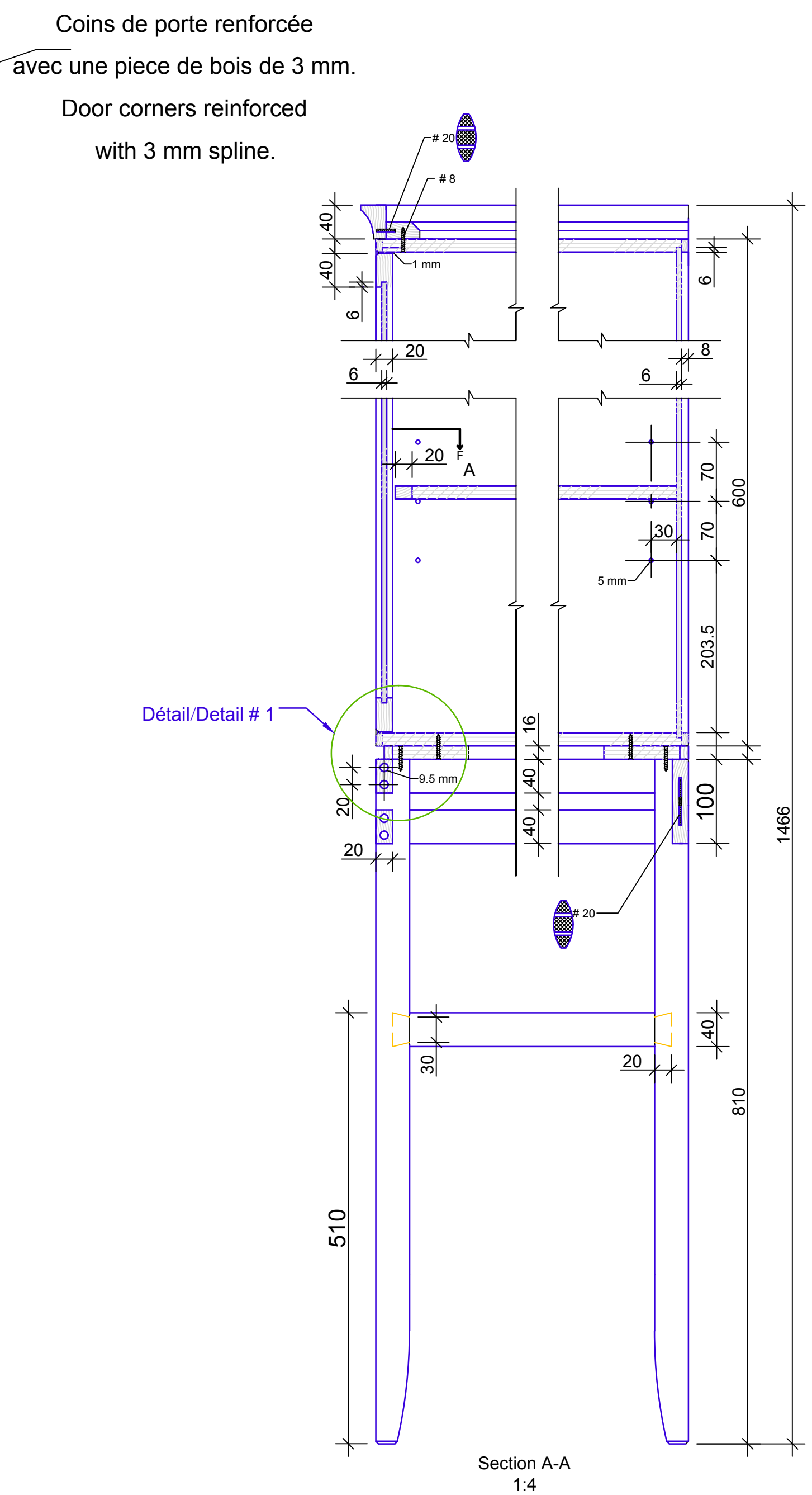
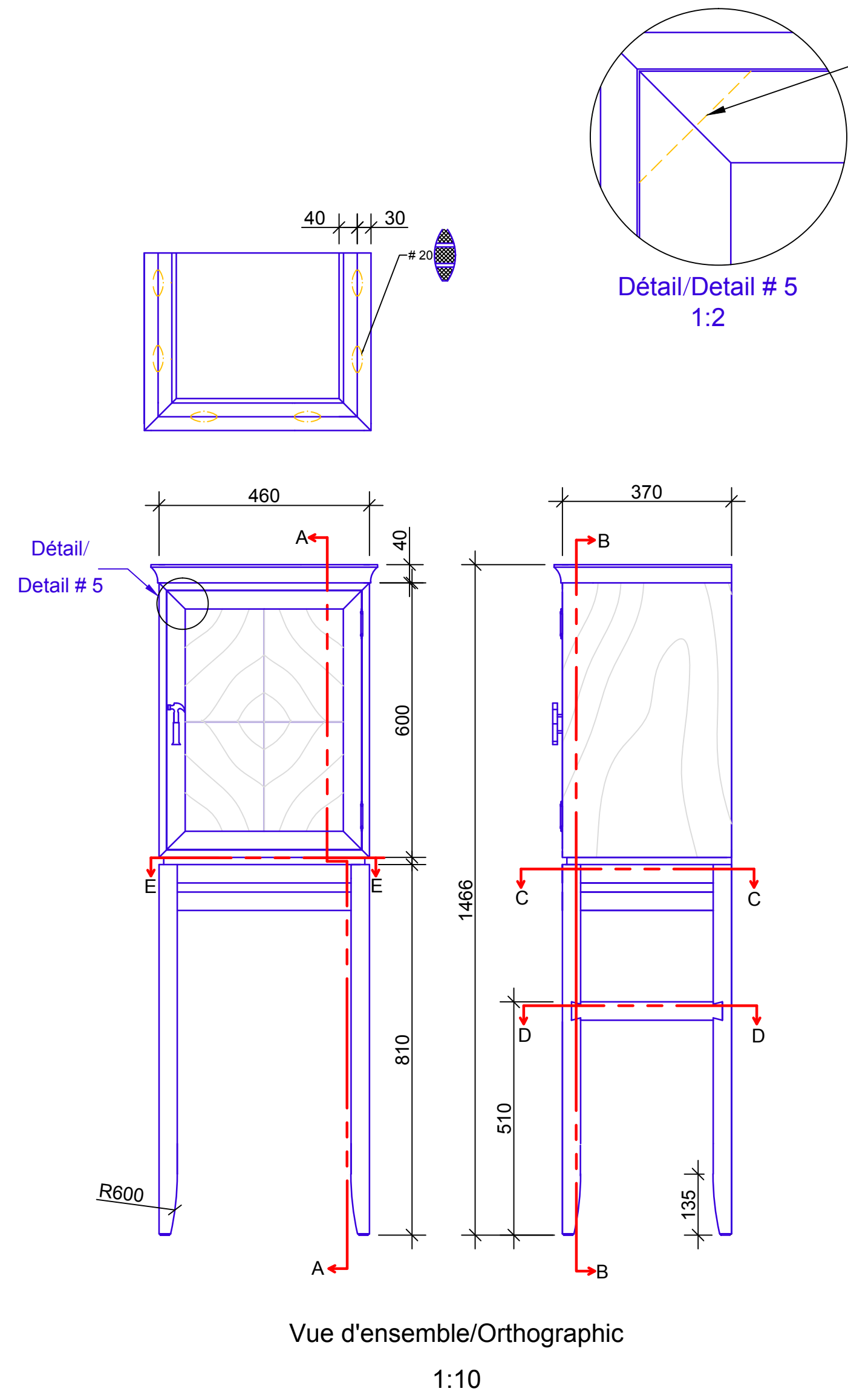

Coins de porte renforcée  
avec une pièce de bois de 3 mm.  
Door corners reinforced  
with 3 mm spline.

Skills/Compétences Canada Concours National/National Competition 2017 Projet d'ébénisterie/Cabinetmaking Project	Métier/Skill 24	Date/Jour 2 Janvier, 2017 January 2, 2016
	L'échelle/Scale: Comme il est Indiqué/As Noted	Dessiné par/ Drawn by: MM