

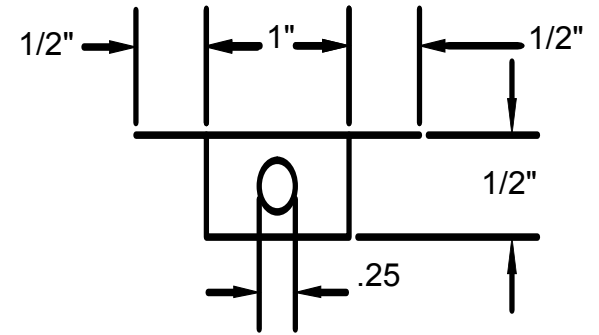

TEST PROJECT / PROJET D'ÉPREUVE

# SHEET METAL TOLERIE

POST-SECONDARY /  
NIVEAU POSTSECONDAIRE

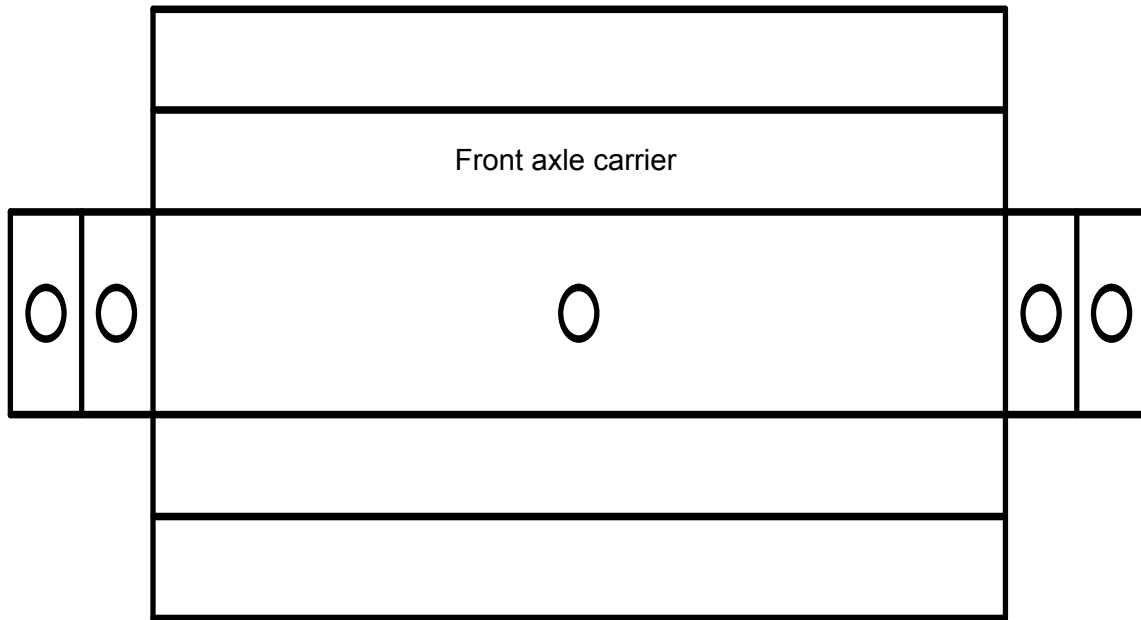

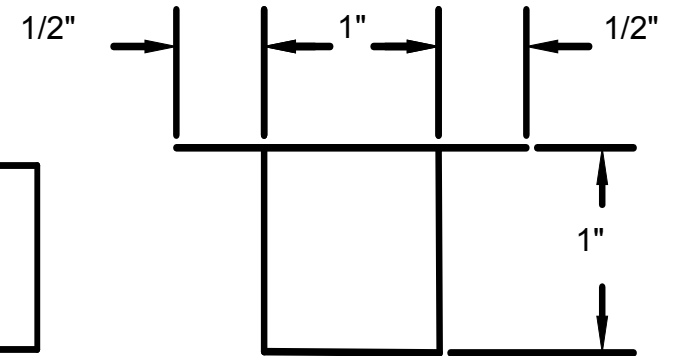
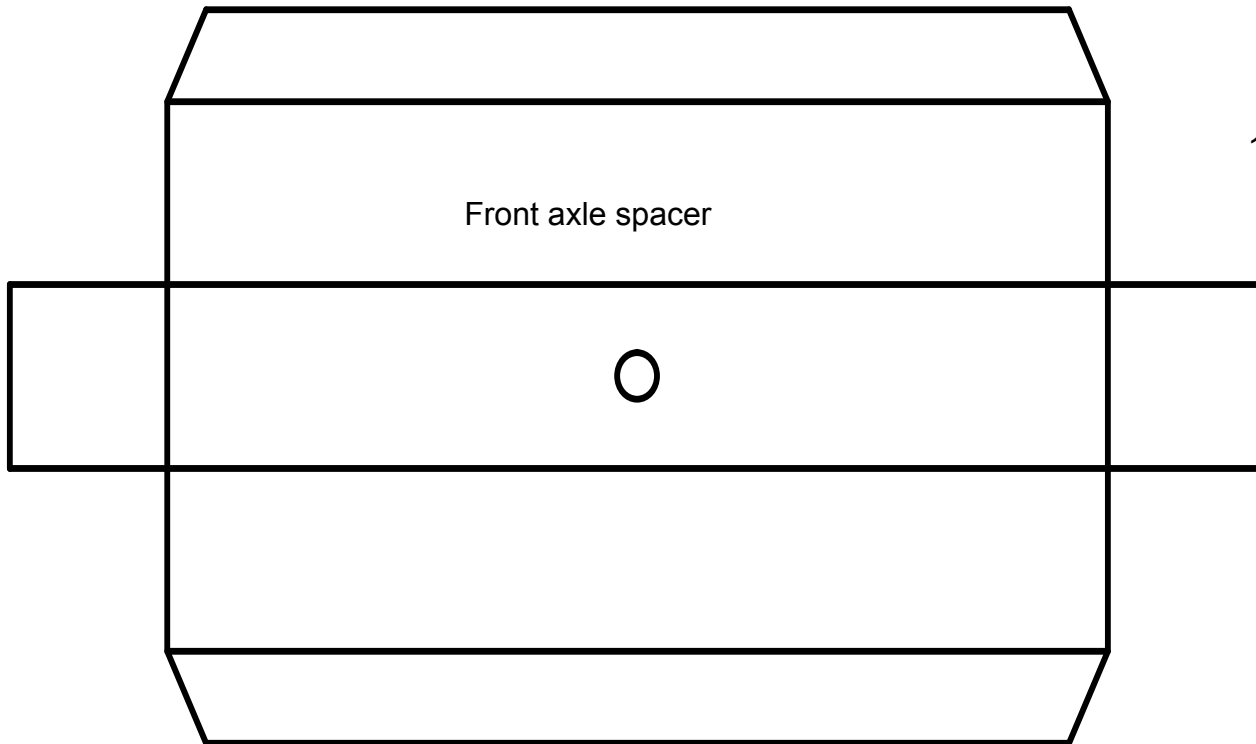

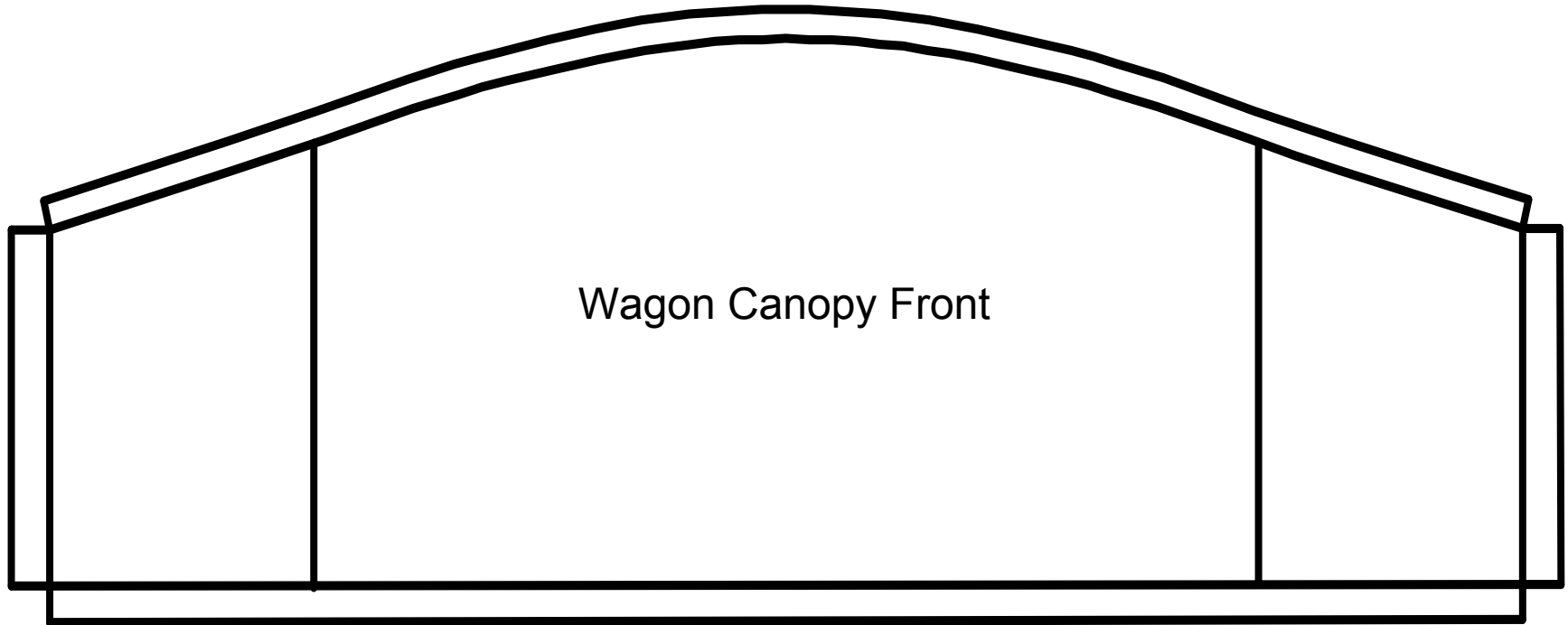

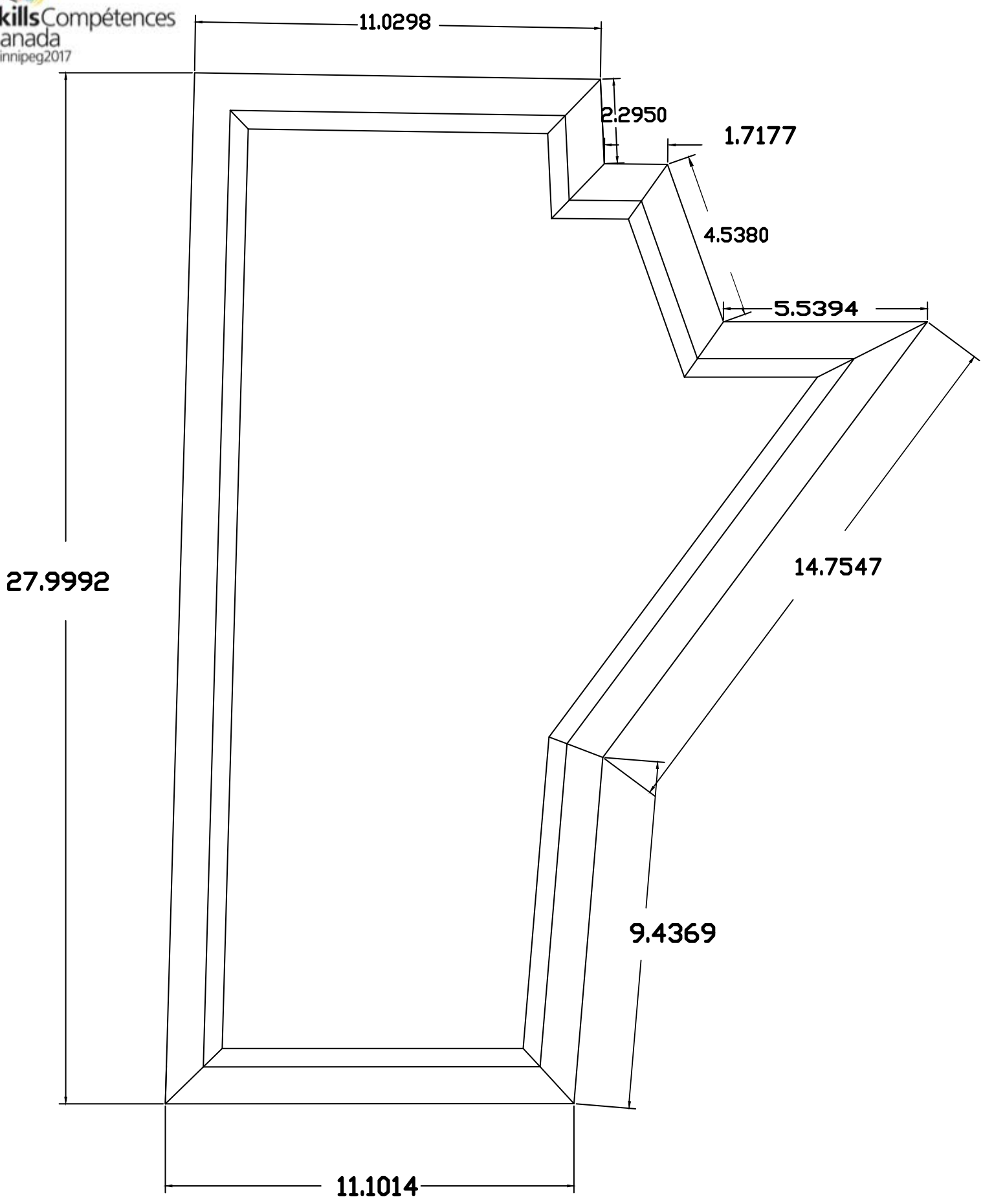

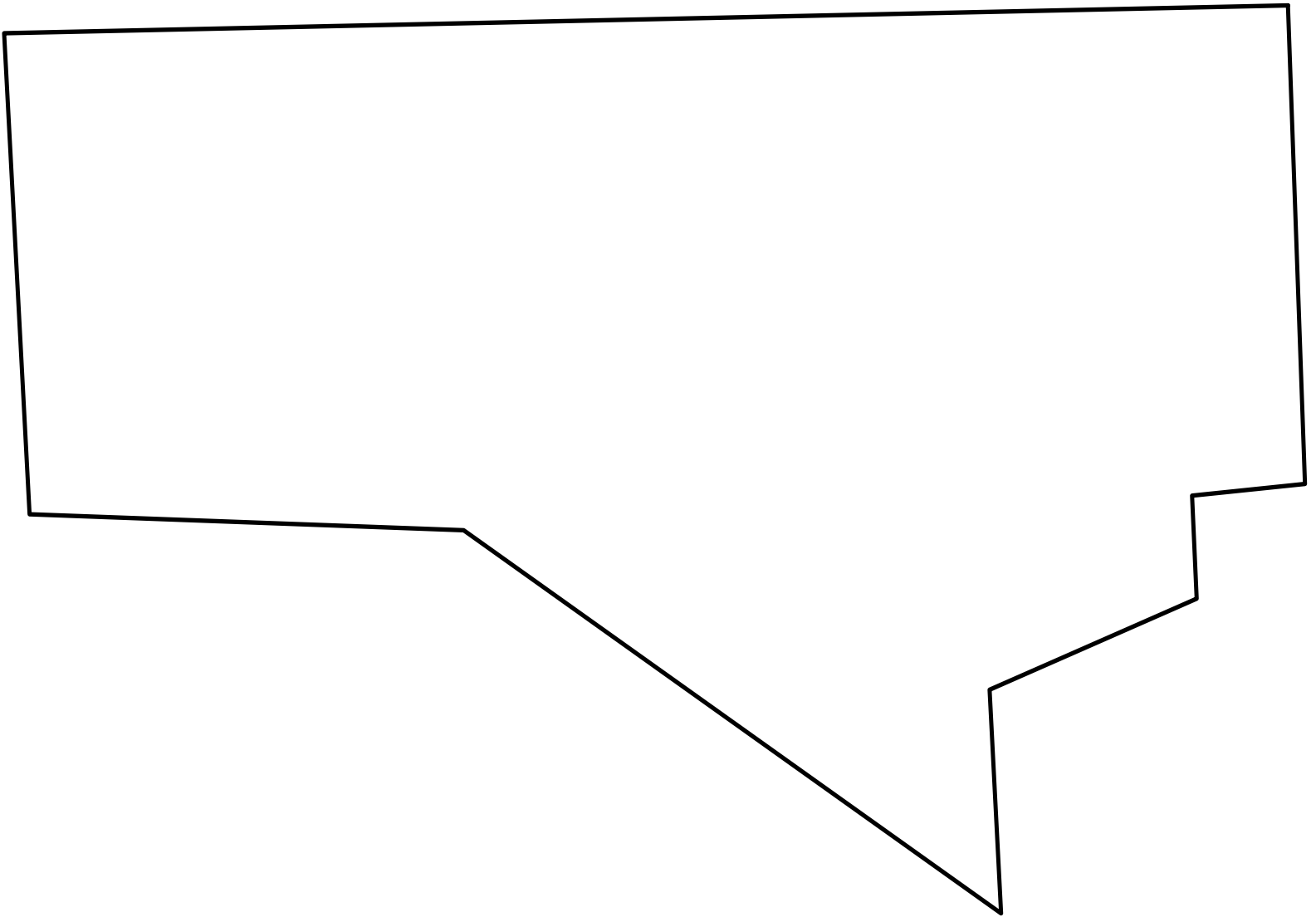

18 Ga. Black Iron Base Pattern  
(All seams solid welded)

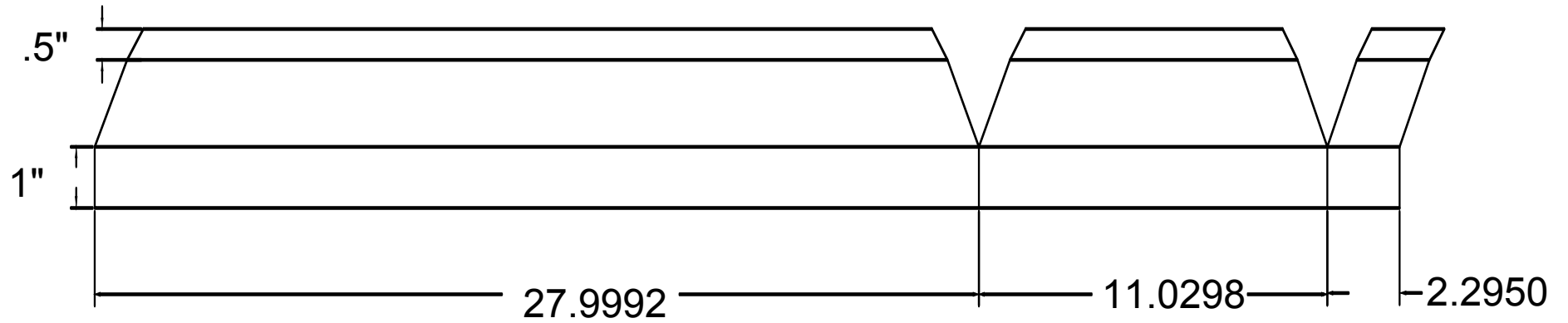

18 Ga. Black Iron Base Pattern  
(All seams solid welded)

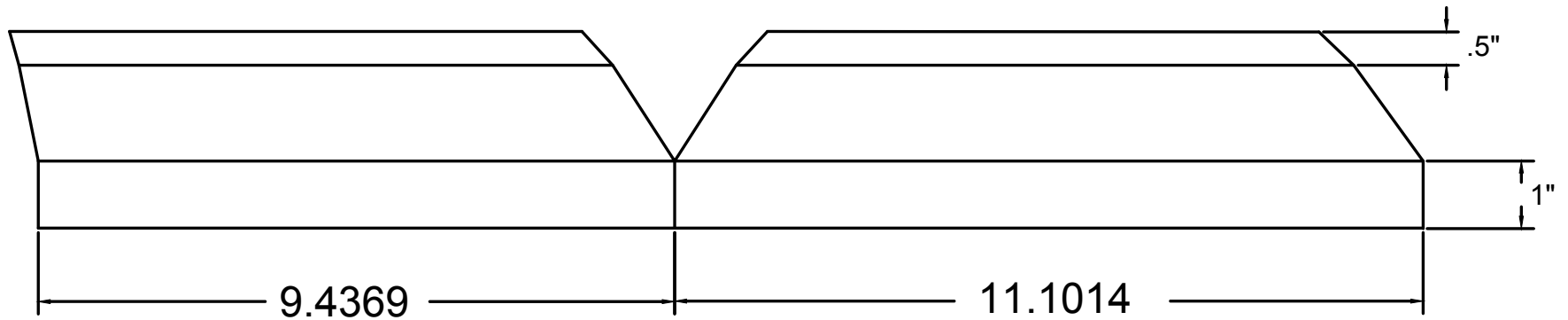



18 Ga. Black Iron Base Pattern  
(All seams solid welded)

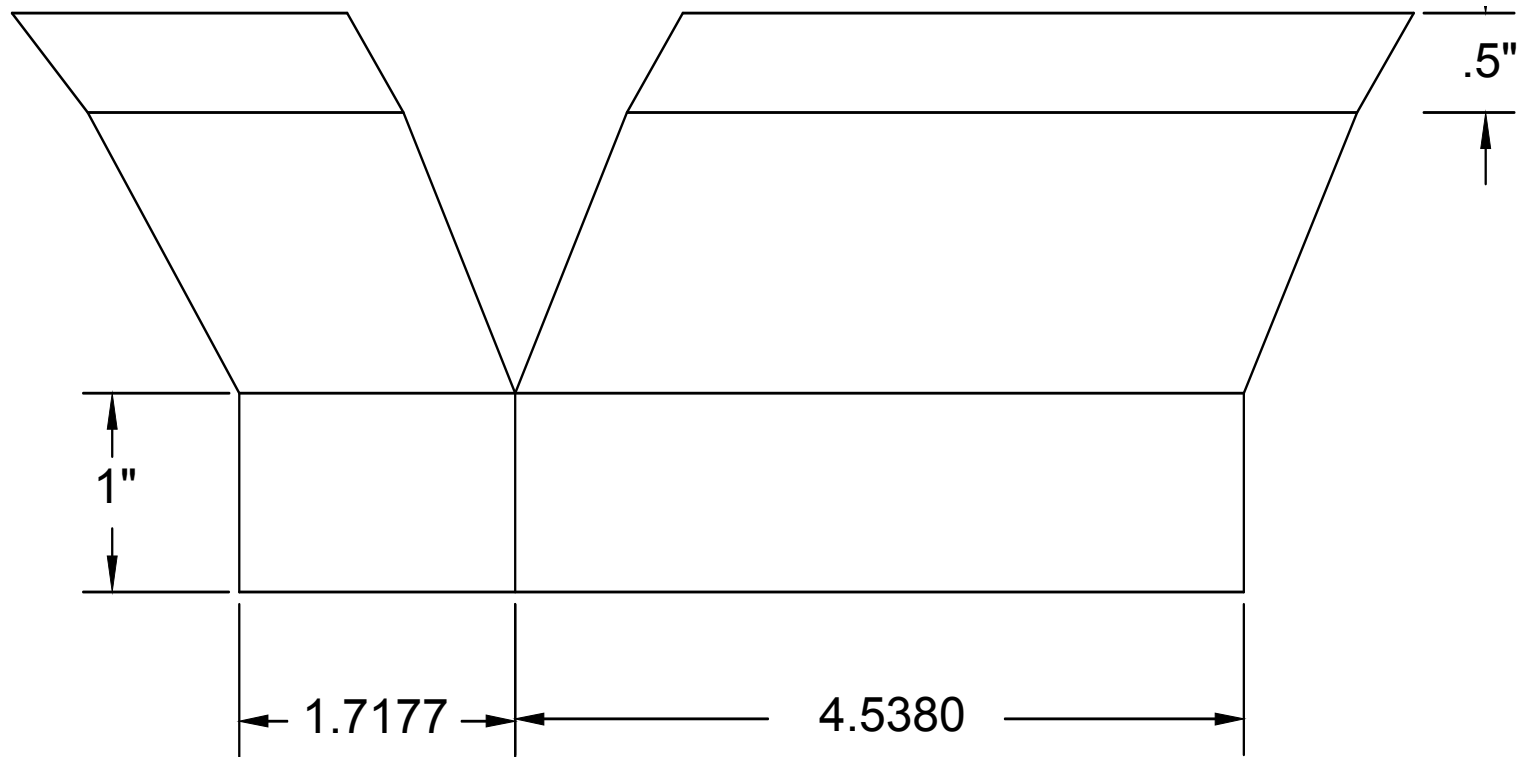

## 18 Ga. Black Iron Base Pattern (All seams solid welded)

